

Complexation and (Templated) Synthesis of Rhenium Complexes with Cyclodextrins and Cyclodextrin Dimers in Water

Kjeld J. C. van Bommel,^[a, b] Menno R. de Jong,^[a] Gerald A. Metselaar,^[a] Willem Verboom,^[a] Jurriaan Huskens,^[a] Ron Hulst,^[c] Huub Kooijman,^[d] Anthony L. Spek,^[d] and David N. Reinhoudt*^[a]

Abstract: Several small, lipophilic rhenium complexes form inclusion complexes with native β -cyclodextrin (β -CD) and β -CD dimers. Association constants larger than 10^9 M^{-1} were obtained using dimers. The use of β -CD also enabled the synthesis of these rhenium complexes in water, in excellent yields, through complexation of the

otherwise insoluble corresponding ligands. The influence of the reaction time and temperature on the configura-

Keywords: cyclodextrins • radiopharmaceuticals • rhenium • supramolecular chemistry • templated synthesis

tion of the reaction products has been investigated in depth for one of these complexes. Using a β -CD dimer, it proved possible to specifically template the formation of one configuration. The strength of the complexes of the rhenium complexes in cyclodextrin dimers may allow radiolabeling of biomolecules.

Introduction

Much research has been done over the last decades on the use of technetium and rhenium for radiopharmaceutical applications,^[1] because of the favorable nuclear properties and easy availability of $^{99\text{m}}\text{Tc}$, ^{186}Re , and ^{188}Re . Radiopharmaceuticals, like other drugs, usually need to be water-soluble in order to be of practical use. Furthermore, for practical reasons, complexes generally must be synthesized under aqueous conditions, starting from sodium perrhenate. The required

water solubility limits the applicability of lipophilic, and hence non-water-soluble complexes as well as the choice of ligands that can be used for complex formation.

β -Cyclodextrin (β -CD, Figure 1) and CD dimers can be used for the complexation of a variety of guest species.^[2] Usually, complexation in a cyclodextrin cavity improves the

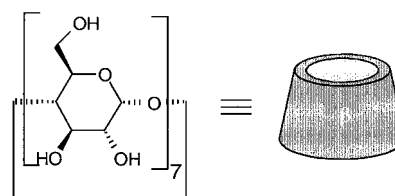

Figure 1. Structure of β -cyclodextrin (β -CD).

solubility of hydrophobic guests in water. Among the most interesting applications of these inclusion complexes is their use in medicine.^[3–6] The use of cyclodextrin derivatives in drug delivery or controlled release systems is extensively studied,^[7] as they are attractive carriers due to their low toxicity and the possibility to tune their delivery properties through chemical modification. Although the advantageous effects of CD complexation of certain drugs have been described extensively,^[8–10] examples of their use in combination with radiopharmaceuticals remain scarce.^[11, 12]

In this article native β -CD as well as β -CD dimers are used to form complexes with non-water-soluble rhenium complexes in order to introduce the water solubility required for

[a] Prof. Dr. Ir. D. N. Reinhoudt, Dr. Ir. K. J. C. van Bommel, Dr. M. R. de Jong, Ir. G. A. Metselaar, Dr. W. Verboom, Dr. Ir. J. Huskens
Laboratory of Supramolecular Chemistry and Technology
MESA⁺ Research Institute, University of Twente
P.O. Box 217, 7500 AE Enschede (The Netherlands)
Fax: (+31)53-4894645
E-mail: SMCT@ct.utwente.nl

[b] Dr. Ir. K. J. C. van Bommel
NRG
P.O. Box 25, 1755 ZG Petten (The Netherlands)

[c] Dr. R. Hulst
Department of Chemical Analysis
University of Twente
P.O. Box 217, 7500 AE Enschede (The Netherlands)

[d] Dr. H. Kooijman, Prof. Dr. A. L. Spek^[+]
Bijvoet Center for Biomolecular Research
Department of Crystal and Structural Chemistry
Utrecht University
Padualaan 8, 3584 CH Utrecht (The Netherlands)
E-mail: spea@chem.ruu.nl

[+] Correspondence pertaining to crystallographic studies to this author.

potential use as radiopharmaceuticals. Furthermore, native β -CD has been used to synthesize a variety of rhenium complexes in water by forming inclusion complexes with the precursor ligands. This novel type of cyclodextrin mediated synthesis^[13] greatly improves access to lipophilic metal complexes, which may be capable of crossing the blood–brain barrier.^[1, 11] The effects of the reaction time and temperature on the configurational distribution of one of these complexes have been investigated in depth. Furthermore, an unprecedented stereoselective templation of the formation of a complex has been accomplished by using a β -CD dimer. Finally, the first results in the development of a novel, supramolecular strategy for the radiolabeling of biomolecules are presented.

Results and Discussion

Cyclodextrin complexes of rhenium compounds

Synthesis of the rhenium complexes: Ligands **5**, **10a**, **10b** depicted in Schemes 1 and 2 are all lipophilic and possess moieties that are known to be included in CD cavities, as well as an NS-bidentate ligand part that allows them to form bis(bidentate) complexes with rhenium. Ligand **5** was synthesized in five steps, starting from 4-nitrophenol (**1**) in an overall yield of 66%. Ligands **10a** and **10b** were synthesized in four steps, starting from 1-bromoadamantane (**7**), with overall yields of 67 and 53%, respectively.

Using NBu_4OAc and NaOAc as bases, the ethylene glycol functionalized amidothioliol ligand **5** was treated with $\text{ReO}(\text{PPh}_3)_2\text{Cl}_3$ in methanol to give complex **6** (EG_2Re) in 78% yield (Scheme 1). Its formation was clearly proven by its ^1H NMR spectrum showing the signals of the AB system belonging to the $\text{SCH}_2\text{C}(\text{O})\text{N}$ protons, which are anisochronous due to the presence of the oxo ligand on only one side of the complex. Using the same conditions as for the formation of EG_2Re **6**, the adamantoxyethyl functionalized complex **11a**

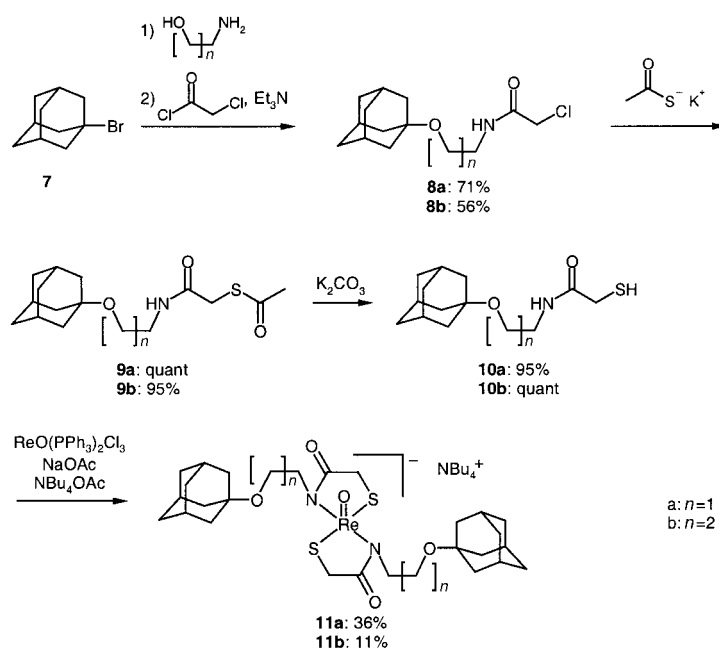

Scheme 2. Synthesis of the complexes AdEt_2Re **11a** and AdPr_2Re **11b**.

(AdEt_2Re) was obtained in a yield of 36%. The ^1H NMR spectrum (Figure 2) shows that the magnetic shielding anisochrony, caused by the oxo ligand, did not only give rise to the appearance of an AB system for the $\text{SCH}_2\text{C}(\text{O})\text{N}$ protons (a/a' in Figure 2), but resulted in different signals for all of the $\text{NCH}_2\text{CH}_2\text{O}$ protons (b/b' and c/c'). Analogously, the adamantoxypropyl functionalized complex **11b** (AdPr_2Re) was obtained in 11% yield. The magnetic shielding anisochrony in the ^1H NMR spectrum, as observed for the complex AdEt_2Re , could also be seen here. However, the two CH_2O protons no longer exhibited different chemical shifts, due to the increased spacer length, which puts them further from the source of the anisochrony (i.e., the oxorhenium core).

The *trans* configuration of compound AdEt_2Re **11a** was proven by X-ray crystal structure determination. Crystals of

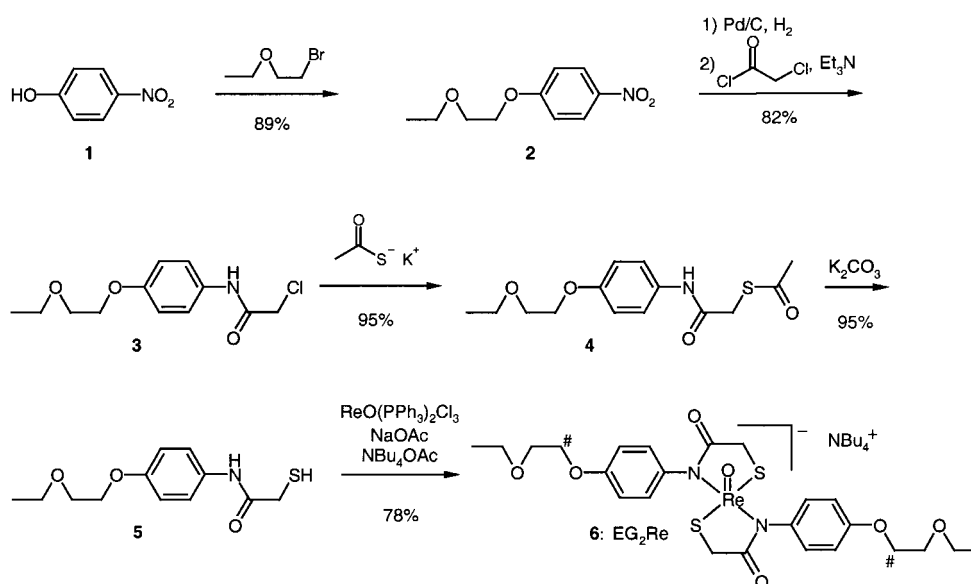

Scheme 1. Synthesis of the complex EG_2Re **6**, see Figure 5 for (#).

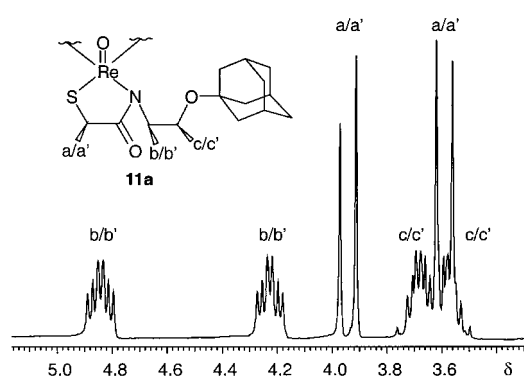

Figure 2. Part of the ^1H NMR spectrum (CDCl_3) of complex AdEt_2Re **11a**. Inset: part of complex **11a**.

AdEt_2Re , obtained by slow evaporation of a methanolic solution of AdEt_2Re , contain two independent AdEt_2Re moieties (see Figure 3). One of these is coordinated to a $[\text{Mg}(\text{MeOH})_4]^{2+}$ ion through the $\text{C}=\text{O}$ group, while the other accepts a hydrogen bond of one of the hydroxyl groups of the $[\text{Mg}(\text{MeOH})_4]^{2+}$ ion.^[14] Both AdEt_2Re moieties clearly show



Figure 3. One of the AdEt_2Re moieties in the X-ray crystal structure of **11a**. Counter-ion omitted for clarity.

that the two bidentate ligands are indeed coordinated to the oxo rhenium core in the expected fashion, that is *S trans* to *S* and *N trans* to *N*. Due to the strong structural resemblance of the complexes and their similar NMR spectra, it is assumed that also in AdPr_2Re **11b** the ligands adopt the same configuration. Although no crystals were obtained of the complex EG_2Re **6**, an X-ray crystal structure of a similar complex displays the *trans* configuration.^[15] Since this compound and EG_2Re only differ in the length of their chains, it is very likely that also EG_2Re adopts the *trans* configuration.

Synthesis of β -cyclodextrin dimers: Three different 2'-connected β -CD dimers have been used (Figure 4). The dimer that contains a benzophenone spacer ($\beta_2\text{benz}$, **12**) was prepared following a strategy, which involves the use of β -cyclodextrin, which is protected at the primary side with *tert*-butyldimethylsilyl (TBDMS) groups. Reaction of 4,4'-bis-(bromomethyl)benzophenone with deprotonated TBDMS- β -cyclodextrin followed by deprotection using tetrabutylammonium fluoride in THF yielded the desired dimer. The synthesis of dimers containing a dipropylamine spacer ($\beta_2\text{dpa}$, **13**) and a dipropylaminodansyl spacer ($\beta_2\text{dans}$, **14**) has been reported previously.^[16]

Complexes with native β -cyclodextrin: EG_2Re **6** was designed to form a 1:2 inclusion complex with native β -CD, through

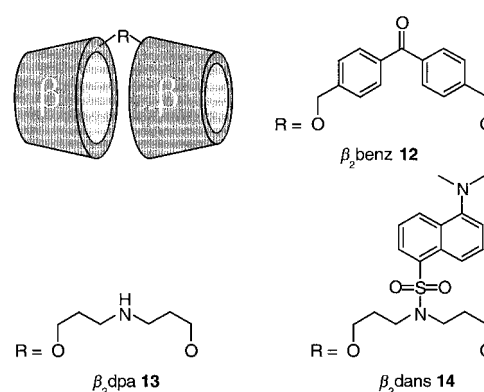

Figure 4. β -CD dimers used for the complexation of small rhenium complexes.

complexation of the two ethylene glycol tails and the connected aromatic rings, inside the β -CD cavities. EG_2Re could be dissolved in D_2O at room temperature up to a concentration of 1.0 mM. Upon the addition of β -CD distinct changes in the ^1H NMR spectrum of EG_2Re were observed. The signals for the two sets of aromatic hydrogens, which happen to be isochronous for EG_2Re , initially shift and then separate to show the expected AB coupling pattern as the concentration of β -CD increases. This indicates the formation of an inclusion complex of β -CD and EG_2Re .

NMR titration data for the complex of β -CD and EG_2Re could be fitted well to a 2:1 binding model with stepwise association constants of $(1.9 \pm 0.3) \times 10^3 \text{ M}^{-1}$ and $(1.0 \pm 0.3) \times 10^3 \text{ M}^{-1}$ for the first and the second β -CD unit, respectively (Figure 5).^[17] Not only does this confirm the formation of the

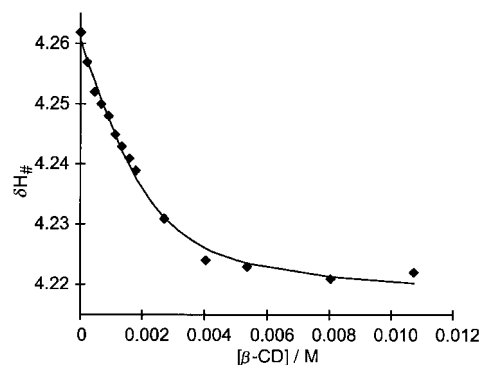

Figure 5. Titration curve for the determination of the stepwise association constants for the complexation of EG_2Re by β -CD. (\blacklozenge : experimental, —: calculated). The proton of which the shift was followed is marked in Scheme 1 (#).

three-component inclusion complex, which could be expected based on the design of the guest, but it also shows the independence of the β -CD binding sites of EG_2Re .

Compounds AdEt_2Re **11a** and AdPr_2Re **11b**, each bearing two adamantyl moieties, were also designed to form a 1:2 inclusion complex with native β -CD, but with much higher association constants. Typical association constants for the complexation of adamantane moieties by native β -CD are known to be in the range of 10^4 – 10^6 M^{-1} .^[18] Due to the

insolubility of AdEt_2Re and AdPr_2Re in water, it was not possible to perform a titration as was done in the case of compound EG_2Re **6**. Although no association constant was obtained, **11a** and **11b** could be made water-soluble by the addition of β -CD. Complexation of the two adamantane compounds by native β -CD was proven by ^1H NMR spectroscopy (ROESY), which showed strong ROE contacts between the protons of the adamantane moieties and the protons H-3 and H-5, at the inside of the β -CD cavity. Part of a representative ROESY spectrum, shown in Figure 6, clearly shows the ROE contacts observed for the inclusion complex formed between **11a** and β -CD.

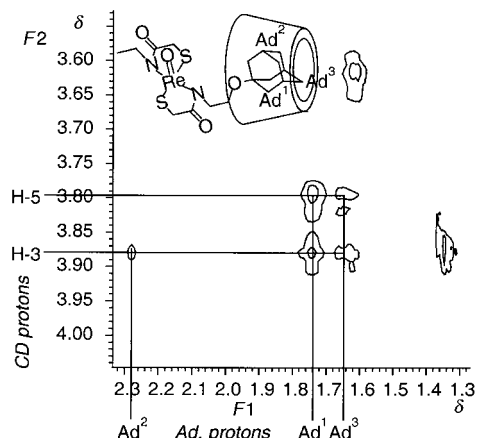

Figure 6. Part of the ROESY spectrum of the inclusion complex of AdEt_2Re **11a** and β -CD (H-3 and H-5 are inner protons of β -CD).

Complexes with β -cyclodextrin dimers: The three different 2'-connected β -CD dimers which have been used possess different properties. The β -CD dimer $\beta_2\text{benz}$ **12** was designed to form complexes with large hydrophobic guests by a cooperative effect of the two β -CD moieties. The benzophenone (benz) spacer makes this dimer rather rigid and hence not very capable of adjusting itself to facilitate binding of guest species that do not exactly fit. The second β -CD dimer, $\beta_2\text{dpa}$ **13**, was designed for similar purposes as dimer $\beta_2\text{benz}$. However, its more flexible dipropylamine (dpa) spacer allows it to adjust itself in order to facilitate binding of different guest species. Finally, dimer $\beta_2\text{dans}$ **14**, carrying a fluorescent dansyl moiety, allows the determination of association constants through fluorescence titrations.^[16] When dissolved in water, the dansyl moiety partly resides in the combined cavities of the β -CD dimer. Upon complexation of a suitable guest species, the dansyl moiety experiences another polarity of the surroundings, leading to a change in fluorescence intensity.

The complexation behavior of EG_2Re **6** with the β -CD dimer $\beta_2\text{benz}$ **12** was studied in water using the continuous variation method (Job's plot) (Figure 7).^[19] The change in chemical shift of H^* (marked in Figure 7) relative to the chemical shift for $\beta_2\text{benz}$, divided by the maximal chemical shift change, multiplied by the concentration of $\beta_2\text{benz}$ is a measure for the concentration of supercomplex $\text{EG}_2\text{Re} \subset \beta_2\text{benz}$. This was plotted against the molfraction of β -CD dimer ($\beta_2\text{benz}$). The plot shows a maximum close to 0.5,

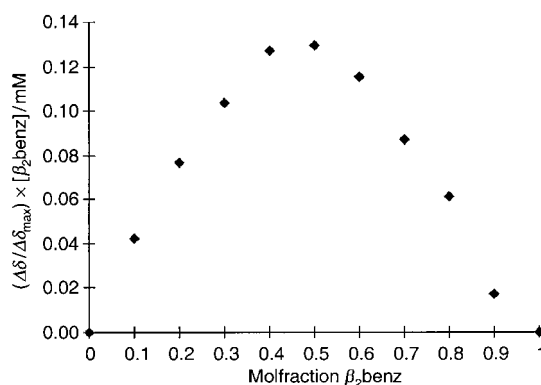

Figure 7. Job's plot to determine the stoichiometry of the inclusion complex of EG_2Re **6** with $\beta_2\text{benz}$ **12**. The shift of the aromatic protons *ortho* to the carbonyl of the benzophenone spacer of **12** was followed.

proving the expected 1:1 stoichiometry.^[20] The corresponding association constant is $(5.5 \pm 0.6) \times 10^3 \text{ M}^{-1}$, showing a weakly cooperative binding when compared to the binding in native β -cyclodextrin.

The most likely mode of complexation would be the threading of the ethylene glycol tails through the β -CDs, followed by binding of the aromatic rings inside the β -CD.^[21] Although both components show substantial changes in their ^1H NMR signals upon complexation of EG_2Re by dimer $\beta_2\text{benz}$, no NOE contacts between EG_2Re and $\beta_2\text{benz}$ could be observed. This is probably due to a rather loose fit of EG_2Re in $\beta_2\text{benz}$, as also suggested by the moderate association constant and the weak cooperative effect. Although no conclusive structural information could be obtained for the superstructure of $\text{EG}_2\text{Re} \subset \beta_2\text{benz}$, the large chemical shifts observed upon mixing of EG_2Re and $\beta_2\text{benz}$ and the observed 1:1 stoichiometry, strongly suggest that complexation occurs inside the β -CD cavities.

Due to the aforementioned insolubility of complex AdEt_2Re **11a** in water, no ^1H NMR titration experiments could be performed to determine the binding constants of AdEt_2Re with β -CD dimers $\beta_2\text{benz}$ (**12**) and $\beta_2\text{dpa}$ (**13**). However, ^1H NMR experiments showing strong NOE contacts between the protons of the adamantane moieties and the protons H-3 and H-5 on the inside of the β -CD moieties of both dimers, proved the formation of the supercomplexes $\text{AdEt}_2\text{Re} \subset \beta_2\text{benz}$ and $\text{AdEt}_2\text{Re} \subset \beta_2\text{dpa}$. To be able to determine the association constant for the complexation of AdEt_2Re **11a** by a β -CD dimer, dimer $\beta_2\text{dans}$ **14** was used. With a structure comparable to that of the dimer $\beta_2\text{dpa}$ **13**, the two dimers should display similar binding behavior. The presence of a fluorescent probe in $\beta_2\text{dans}$ **14** makes it possible to determine association constants by means of a series of fluorescence titrations. They were performed in different water/methanol mixtures, since complex AdEt_2Re **11a** could be dissolved in mixtures with up to 80% water. Similarly, association constants were determined for AdPr_2Re **11b**, which differs from AdEt_2Re **11a** only in the length of the carbon chains linking the adamantane moieties to the ligating part of the complex. The association constants found for the complexation of the bis(adamantane) guests by the β -CD dimer ranged from about 10^6 M^{-1} in $\text{MeOH}/\text{H}_2\text{O}$ 50:50 to about 10^8 M^{-1} in $\text{MeOH}/\text{H}_2\text{O}$ 20:80.^[22]

The influence of a binary solvent medium on the association constants for binding of a guest by β -CD has been studied by Connors et al., who dissected the free energy change for complex formation in contributions stemming from solvent–solvent interactions (the general medium effect), solvent–solute interactions (the solvation effect), and solute–solute interactions (the intersolute effect).^[23] In order to find the association constant for the binding of the bisadamantane guest by the CD dimer in 100% water, an extrapolation of the binding constants observed in the methanol/water mixtures is needed. Of the three factors described by Connors et al., the part describing the solvent–solvent interactions can be used as is, since in both cases a methanol/water system is studied. Although the system described by Connors et al. deals with complexation of a guest by α -CD, the interactions between β -CD (used here) and the solvents are here assumed identical. Since the factor describing the solute–solute interactions is considered to be independent of the medium (i.e., the ΔG of complex formation in pure water), it is possible to fit a curve to the experimental datapoints, which can be extrapolated to give the association constant in 100% water. Both in the case of AdEt₂Re **11a** and AdPr₂Re **11b**, the same set of parameters^[24] was used to fit the curves to the datapoints (Figure 8).

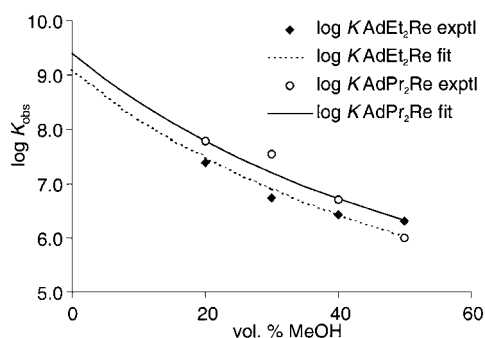

Figure 8. Determination of the association constants for the complexation of AdEt₂Re **11a** and AdPr₂Re **11b**, by β -CD dimer β_2 dans **14**.

By extrapolation of the curve, a K value of $\approx 10^9 \text{ M}^{-1}$ for the complexation of AdEt₂Re **11a** by β_2 dans **14** in 100% water (Figure 8) was found. This indeed shows that the adapted design of the guest (i.e., the introduction of the more bulky adamantane moieties) results in a dramatic increase in the association constant. A determination of the association constant for the complexation of AdPr₂Re **11b** by β_2 dans **14** in 100% water, again through extrapolation, resulted in a higher association constant (Figure 8).^[25] From this, it is clear that fine-tuning of the association constant is possible by relatively small adjustments to the structure of the guest. It was found that the association constants for guests in dimer β_2 dpa **13** are generally larger than those obtained using dimer β_2 dans **14**, owing to enhanced cooperativity of the cavities in **13**.^[16] With binding constants of this magnitude, supercomplexes such as AdEt₂Re \subset β_2 dpa rather than the “guest complex” AdEt₂Re **11a** may be considered the actual radiopharmaceutical.^[6]

These results show that several non-water-soluble and inherently lipophilic rhenium complexes can be made water-soluble by the addition of β -CD, thus widening the range of complexes that can be used in nuclear medicine. The numerous possibilities to tune the strength of the association complexes offer interesting opportunities for the controlled release of radiopharmaceuticals.^[26]

Cyclodextrin-mediated complex formation: In nuclear medicine, complexes must be synthesized starting from an aqueous solution of sodium perrhenate, as this is the sole source of ¹⁸⁸Re. Like the analogous technetium(v) gluconate,^[27] rhenium(v) gluconate^[28] is often used as a precursor for the preparation of rhenium(v) complexes. Exchange reactions with appropriate ligands may be carried out in aqueous or aqueous/organic solutions and the resulting Re complexes are, as a rule, of high (radiochemical) purity. However, the required water solubility limits the use of lipophilic ligands. Cyclodextrins are known to mediate a variety of organic reactions,^[13] but to the best of our knowledge they have so far not been used to mediate the formation of otherwise water insoluble metal complexes. Here we present the cyclodextrin mediated formation of metal complexes of water insoluble ligands in aqueous solution, starting from the precursor rhenium(v) gluconate.^[29]

Native CD-mediated synthesis: Being slightly water-soluble, the NS ligand functionalized with an ethylene glycol chain **5** could be used to synthesize the complex EG₂Re **6** under aqueous conditions. Hereto a rhenium gluconate solution was adjusted to pH 10 by 1N NaOH and the ligand **5**, dissolved in a minimal amount of MeOH, was added. After 1 h, one equivalent of NBu₄Cl was added^[30] and the mixture was extracted with chloroform to give analytically pure EG₂Re **6** in good yield (83%). In order to perform the reaction in the absence of any organic solvent, the ligand **5** was dissolved in pure water as its β -CD complex. Performing the complex formation as described above (1 h, RT) resulted in the isolation of EG₂Re in even higher yield (93%). Analysis of both products proved them identical to the ones synthesized in organic solvents.

The more lipophilic adamantane ligand **10a** could only be dissolved in water by complexing it with β -CD. Performing the reaction as described above (1 h, RT) resulted in the isolation of a mixture of two products in an overall yield of 95%. These products could not be separated, so analyses were done on the mixture, rather than the pure compounds. The ¹H NMR spectrum showed that one of these products was identical to AdEt₂Re (**11a**) when synthesized in organic solvents. The other product displayed very similar signals, but at different positions.^[31] Both FAB-MS and elemental analysis indicated a composition identical to AdEt₂Re. This strongly suggests that the second product is the *cis* configuration of complex AdEt₂Re.^[32] The formation of both isomers of complex AdEt₂Re (i.e., *trans*-**11a** and *cis*-**11a**) is depicted schematically in Scheme 3. The ratio of *cis*-AdEt₂Re:*trans*-AdEt₂Re, as determined by integration of their ¹H NMR signals, was 15:85 (entry 1, Table 1).

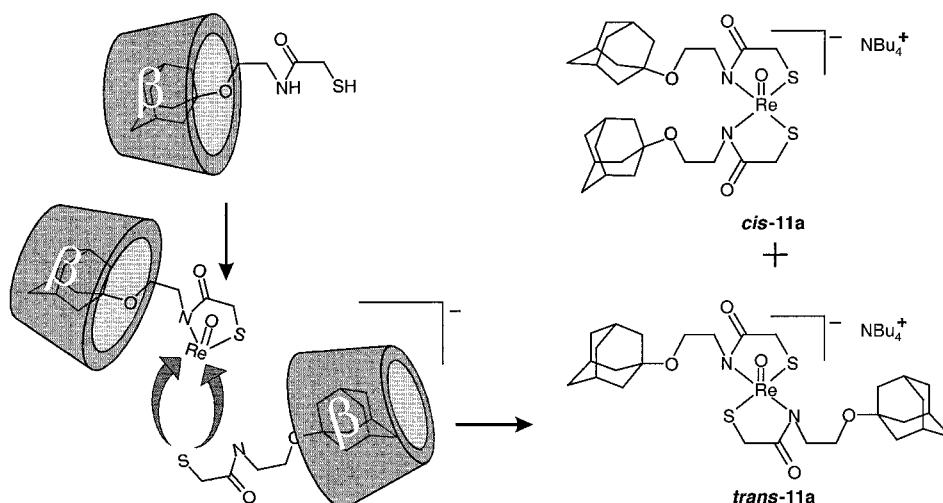
Scheme 3. β -CD facilitated formation of AdEt_2Re (*cis* and *trans*).Table 1. Relative yields of *cis*- AdEt_2Re (*cis*-**11a**) and *trans*- AdEt_2Re (*trans*-**11a**) for different t and T (total yields for all entries > 95%).

	t_1 [h]	T_1 [°C]	t_2 [h]	T_2 [°C]	% <i>cis</i> ^[a]	% <i>trans</i> ^[a]
1	1	RT	–	–	15	85
2	1	0	–	–	51	49
3	1	0	1.5	0	22	78
4	1	0	1.5	55	6	94
5	1	55	1.5	55	<1	>99

[a] Determined by ^1H NMR; error \pm 2%.

To investigate the time and temperature dependence of this ratio, the same reaction was performed for different times and at different temperatures, keeping all other conditions the same (Table 1). For all entries the total yield of isolated complex (*cis*+*trans*) was >95%. A comparison of entries 2 and 3 shows that an increase in reaction time results in a shift in the ratio *cis*- AdEt_2Re :*trans*- AdEt_2Re in favor of the latter; this indicates that the *cis* product is converted into the *trans* product.

A comparison of entries 3 and 4 shows that the *cis/trans* conversion proceeds faster at elevated temperatures. Finally, entry 5 shows that when the reaction is carried out at 55 °C for the whole 2.5 h the *trans* product is formed almost exclusively. Apparently, the complex formation reaction initially gives a mixture of the *cis* and *trans* products, followed by complete conversion into the thermodynamically more stable *trans* product. Applying the same reaction conditions (i.e., 2.5 h at 55 °C) to the formation of AdPr_2Re **11b** in water, starting from the ligand **10b**, gave exclusively the expected *trans* complex in 95% yield.

Refluxing a chloroform solution of the *cis/trans* mixture of entry 2 for a period of 5 h (61 °C) did not result in a change in the ratio of *cis*- AdEt_2Re :*trans*- AdEt_2Re . Redissolving the same mixture in a basic solution of β -CD and sodium gluconate and stirring

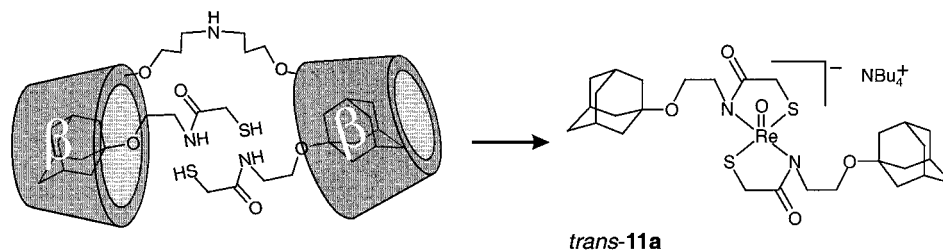
Scheme 4. Templated formation of *trans*- AdEt_2Re **11a** by β -CD dimer $\beta_2\text{dpa}$ **13**.

this at 0 °C for 1.5 h, resulted in a *cis* to *trans* ratio of 25:75. Having undergone identical reaction periods and times as those used for entry 3 (i.e., 1 h+1.5 h at 0 °C), this sample shows a ratio that is in good agreement with the ratio observed for entry 3. Redissolving several *cis:trans* mixtures in aqueous solutions only containing β -CD (i.e., no sodium gluconate and NaOH) and stirring for 24 h at room temperature, never resulted in a change of these ratios. These results clearly show that the *cis/trans* conversion can only take place under the reaction conditions

used for the complex formation and that when a mixture is isolated and subsequently resubjected to these reaction conditions this conversion can again continue to take place. This strongly suggests the fast formation of a kinetic product or product mixture that is unstable under the reaction conditions, allowing it to be slowly interconverted to the thermodynamic product.

β -CD dimer templated synthesis: Owing to the orientation of the β -CD cavities of the dimers, they should be capable of preorganizing two molecules of the bidentate ligand **10a** in such a way that complex formation can only take place in a *trans* fashion rather than a *cis* fashion (Scheme 4).^[33] To investigate whether β -CD dimer $\beta_2\text{dpa}$ **13** could indeed template^[34] the formation of *trans*- AdEt_2Re , *trans*-**11a**, a reaction was performed under exactly the same conditions as used for entry 2 of Table 1, but using β -CD dimer $\beta_2\text{dpa}$ instead of native β -CD (0.55 equiv per ligand). Whereas for entry 2 the *cis* to *trans* ratio was 51:49, the ^1H NMR spectrum of the obtained product, using the β -CD dimer $\beta_2\text{dpa}$ (0 °C, 1 h), showed 100% of the *trans* product and no detectable signals of the *cis* product. The complex was obtained in 96% yield and the template $\beta_2\text{dpa}$, used in this reaction, could be recovered in 83% yield by dialysis of the aqueous phase. This excellently proves that β -CD dimer $\beta_2\text{dpa}$ is an efficient and reusable template for the formation of a metal complex. To the best of our knowledge, this is the *first* example of a *stereoselective* complex formation that is templated by a supramolecular system.

In all cases described, the yields for cyclodextrin-mediated rhenium complex formation in water are much higher than those for the synthesis of the same complexes in organic solvents. This clearly demonstrates cyclodextrin-mediated synthesis to be a powerful new tool, granting easy access to a range of lipophilic rhenium complexes that can be further extended by using α - or γ -cyclodextrin. The rapid reaction and absence of impurities render this method interesting for radiopharmaceutical applications, as these characteristics reduce loss of radioactivity to a minimum. Adding to the versatility of the method is the control over the stereochemistry of the product. The *trans* isomer of the complex can be obtained exclusively by performing the reaction at elevated temperatures. If heating is prohibited because the ligand systems used are prone to decomposition or racemization, a β -CD dimer may be used to template the formation of this isomer. Conversely, shorter reaction times or CD dimers with another geometry may enable the isolation of the *cis* complex.

A mixed ligand complex: Katzenellenbogen et al.^[35, 36] have described the preferential formation of heterodimeric bis(bidentate) rhenium and technetium complexes in organic solvents. To investigate the possibility of synthesizing this type of complexes in water, and to see whether the same preferences could be observed when performing β -CD facilitated rhenium complex formations, the synthesis of the neutral heterodimeric bis(bidentate) N_2S_2 rhenium complex AdPr-Pyr-Re **18** was carried out.

Hereto the bidentate pyridine ligand **17** was synthesized in two steps, starting from 2-picolyl chloride **15** (Scheme 5).

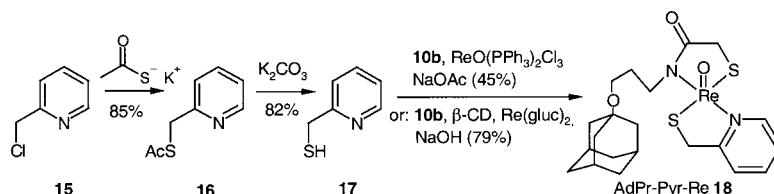

Scheme 5. Synthesis of the neutral heterodimeric bis(bidentate) N_2S_2 rhenium complex AdPr-Pyr-Re **18** in organic solvents and in water.

Using equimolar amounts of the ligands **17** and **10b**, the heterodimeric bis(bidentate) rhenium complex **18** was first synthesized in organic solvents (MeOH/ $CHCl_3$). The 1H NMR spectrum of the crude reaction product showed that three bis(bidentate) complexes (i.e., AdPr-Pyr-Re **18**, AdPr₂Re **11b**, and Pyr₂Re) had been formed, their ratios being about 10:1:1 (as estimated from the 1H NMR spectrum). The desired complex AdPr-Pyr-Re **18** was obtained in 45% yield after flash column chromatography^[37, 38] and its 1H NMR spectrum (Figure 9) clearly displayed the expected two AB systems belonging to the SCH_2 protons of both the adamantane and the pyridine ligand in a 1:1 ratio. Since the pyridine ligand only carries one negative charge, the resulting complex is neutral, rather than mono-anionic as was the case for the previously described N_2S_2 complexes.

By adding β -CD, the ligands **17** and **10b** could be dissolved in water,^[39] making it possible to form AdPr-Pyr-Re **18** in

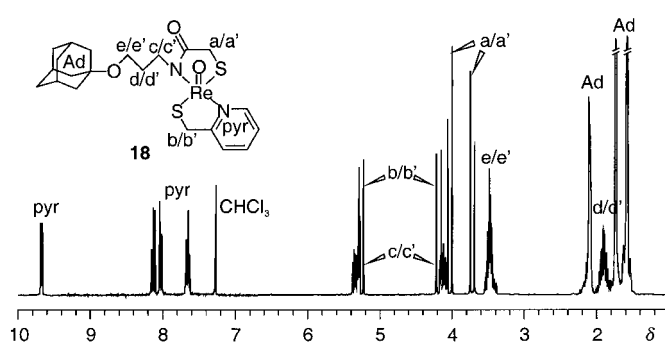

Figure 9. 1H NMR spectrum in $CDCl_3$ of complex AdPr-Pyr-Re **18**.

water with rhenium(v) gluconate as a precursor complex. To avoid the formation of mixtures of *cis* and *trans* complexes, the reaction mixture was stirred at $55^\circ C$ for 5 h (see above). The 1H NMR spectrum of the crude reaction product again showed the formation of all three bis(bidentate) complexes in ratios similar to those observed when performing the synthesis in organic solvents. However, due to the nearly complete absence of side products,^[40] the desired product AdPr-Pyr-Re **18** could be obtained in 79% yield after flash column chromatography. Analysis proved it to be identical to the complex obtained by synthesis in organic solvents.

Confirmation for the *trans* configuration of the complex AdPr-Pyr-Re **18** came from its X-ray crystal structure (Figure 10). This clearly shows the orientation of the two bidentate ligands, resulting in an N *trans* to N and S *trans* to S arrangement around the oxo rhenium core.

Although the observed preferential formation of the heterodimeric bis(bidentate) complex **18** was not as strong as observed by Katzenellenbogen et al. (99% formation of the heterodimeric bis(bidentate) complex),^[35, 36] a strong preference can still be observed. Performing the reaction in water apparently does not change the general preference to form the mixed ligand complex.

Supramolecular labeling of biomolecules: The known beneficial properties of cyclodextrins for pharmaceutical applications have prompted research efforts to go one step further. In combination with other carrier materials cyclodextrins may offer the possibility to deliver drugs to a targeted site. Several large biologically active peptides have been coupled to

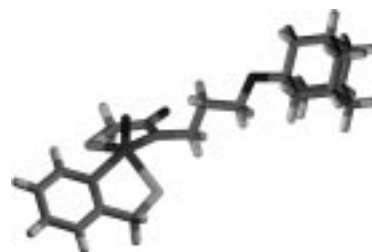
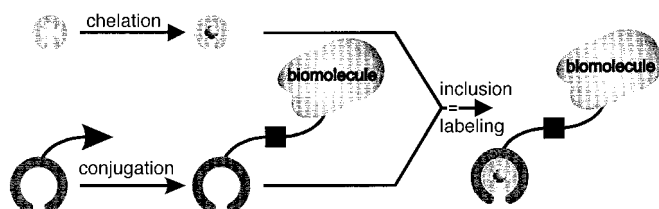

Figure 10. One of the independent AdPr-Pyr-Re molecules in the X-ray crystal structure of the heterodimeric bis(bidentate) rhenium complex **18**.

cyclodextrins.^[41] If a spacer is introduced, neither the interaction of the peptide with its receptor nor the guest binding ability of the cyclodextrin are influenced substantially.^[42] In nuclear medicine, target-specific radiopharmaceuticals are synthesized through both pre- and postlabeling of biomolecules.^[43] Although widely used, both methods have the inherent disadvantage, that a certain degree of radiolysis of the biomolecules will occur since both radioisotope and biomolecule will be present in relatively high concentrations for an extended period of time (i.e., the time required for the conjugation or chelation step, respectively).

The results presented here so far may offer the possibility of a novel, supramolecular approach toward the radiolabeling of biomolecules. Hereto a cavity-containing moiety, that is a CD containing functionality (Scheme 6) is first linked to a biomolecule. The actual labeling step is now the complexation of a small radioisotope complex, which can be synthesized separately. As the complexation will take place almost



Scheme 6. Supramolecular labeling approach.

instantaneously, this approach has the potential to decrease damage to the biomolecule to an absolute minimum. In order for this approach to be successful, a strong complex between the cavity-containing molecule and the radiopharmaceutical is necessary to prevent rapid dissociation of the complex.

Bioconjugation of a β -CD dimer: Biomolecules are often coupled through the reaction between a thiol and a maleimide,^[44] usually after coupling of these moieties to free amino groups of lysine residues. Thus, the amino group of dimer β_2 dpa **13** was functionalized with a thiol group by reaction with the *N*-hydroxysuccinimide ester of *S*-acetylthioacetic acid (SATA), followed by basic hydrolysis of the thioester, using NH_2OH , to give **19** (Scheme 7).^[45]

Cytochrome C (Cyt C), although not a protein used in drug targeting, was used as a model biomolecule because of the high purity in which it is commercially available. The bifunc-

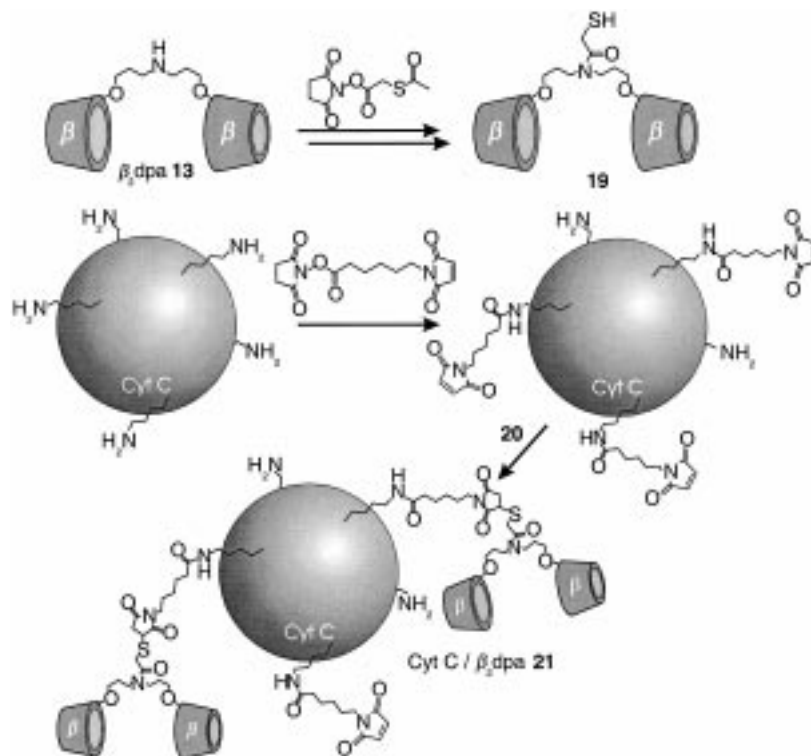

Scheme 7. Synthesis of the cytochrome C/ β -CD dimer conjugate, Cyt C/ β_2 dpa **21** (schematic representation, not to scale).

tional reagent succinimidyl 6-(*N*-maleimido)-*n*-hexanoate (MHS) was linked to Cyt C by reaction with free lysine NH_2 moieties.^[44] After reaction with an excess of MHS, the Cyt C was purified using a PD-10 desalting column packed with Sephadex G-25. Subsequently, the thiol-functionalized β -CD dimer **19** was treated with the maleimide-functionalized Cyt C, followed by dialysis (cutoff $M_w \approx 10000$) to give the dimer functionalized Cyt C **20**.

The MALDI-TOF spectrum showed a large cluster of signals around m/z 13301, belonging to Cyt C functionalized with an average of five maleimide moieties. A smaller signal cluster around m/z 15868 corresponds to Cyt C with five maleimide moieties and one β -CD dimer (calcd mass 15858); this indicates that the strategy to functionalize Cyt C was indeed successful. Microcalorimetric titrations showed that the first additions of a known ditopic guest for cyclodextrin (sodium deoxycholate) to the mixture obtained caused larger exothermic heat effects than the reference experiments, strongly suggesting inclusion of the guest by the cyclodextrin dimer. Although binding constants could not be obtained due to the unknown ratio of functionalized to non-functionalized Cyt C, this proves the principle of the supramolecular labeling of radiopharmaceuticals.

Conclusion

Several small rhenium complexes, synthesized in organic solvents, have been shown to form inclusion complexes with native β -CD, thus becoming water-soluble. Several β -CD dimers form 1:1 inclusion complexes with these rhenium complexes, with association constants $> 10^9 \text{ M}^{-1}$ for the super-complex $\text{AdPr}_2\text{Re} \subset \beta_2\text{dans}$.

Water-solubilizing only the ligands has been shown to be a powerful new tool for the synthesis of very lipophilic rhenium complexes, affording high yields without the need for tedious purification steps. Through cyclodextrin mediated synthesis, homo- as well as heterodimeric bis(bidentate) rhenium complexes could be synthesized, as was proven by their X-ray crystal structures. Variation of reaction time, reaction temperature, or the cyclodextrin derivative used provided excellent control over the configuration of the rhenium complex obtained. Using a cyclodextrin dimer afforded the first example of a stereoselective formation of a metal complex that is templated by a supramolecular system. The high degree of configurational control might make this an interesting new tool not only in pharmacology, but also in the field of coordination chemistry in general. The use of different ligands and of α - and γ -CD can further widen the scope of this approach.

Finally, the use of very strong supercomplexes such as those presented here could be the basis for a novel, supramolecular method for the labeling of biomolecules.

Experimental Section

General information: NMR experiments were performed using a Varian Unity 400 WB NMR spectrometer operating at 400 and 100 MHz for the ^1H and ^{13}C nuclei, respectively. All spectra were recorded in CDCl_3 . ^1H , ^{13}C , COSY,^[46] clean-TOCSY (MLEV17),^[47] NOESY,^[48] and HMQC^[49] experiments were used for the assignment of the ^1H and ^{13}C NMR resonances. All 2D spectra were collected as 2D hyper-complex data.^[50] After weighting with shifted sine-bell functions, the COSY data were Fourier transformed in the absolute value mode while the clean-TOCSY (MLEV17) and HMQC data were transformed in the phase-sensitive mode. All data processing was performed using standard Varian VnmrS/VnmrX software packages. COSY and TOCSY spectra were accumulated typically with 256 increments and 32 scans per increment. In the clean-TOCSY experiments the mixing time of the MLEV17-pulse was arrayed between 30 and 100 ms; in the NOESY experiments mixing times of 30 to 90 ms were applied. Routine experiments were recorded on a Varian Inova NMR spectrometer operating at 300 and 75.5 MHz for ^1H and ^{13}C , respectively. All spectra were recorded in CDCl_3 unless otherwise stated. Residual solvent protons were used as internal standard and chemical shifts are given in ppm relative to tetramethylsilane (TMS). Fast atom bombardment (FAB) mass spectra were measured on a Finnigan MAT 90 spectrometer using *m*-nitrobenzyl alcohol (NBA) as a matrix. Identification of the Cyt C compounds was performed by matrix assisted laser desorption/ionization (MALDI) time-of-flight (TOF) mass spectrometry^[51–53] using a PerSeptive Biosystems Voyager-DE-RP MALDI-TOF mass spectrometer (PerSeptive Biosystems, Inc., Framingham, MA, USA) equipped with delayed extraction.^[54] A 337 nm UV Nitrogen laser producing 3 ns pulses was used and the mass spectra were obtained both in the linear and reflectron mode. Mass assignments were performed with unmanipulated spectra (no smoothing or centering, etc.) for an optimal correlation between observed and calculated masses.

All solvents were purified by standard procedures. All other chemicals were analytically pure and were used without further purification. All reactions were carried out under an inert argon atmosphere. The presence of solvent in the analytical samples was confirmed by ^1H NMR spectroscopy. Melting points (uncorrected) of all compounds were obtained on a Reichert melting point apparatus. The synthesis of compounds **13** ($\beta_2\text{dpa}$) and **14** ($\beta_2\text{dans}$) was published elsewhere.^[16] 4,4'-Bis(bromomethyl)benzophenone^[55] and TBDMS-protected β -cyclodextrin^[56] were prepared by literature procedures.

EG-NO₂ (2):^[57] A mixture of nitrophenol (5.60 g, 40 mmol), 2-bromoethyl-ethyl ether (12.24 g, 80 mmol), and potassium carbonate (11.04 g, 80 mmol) in CH_3CN (200 mL) was heated under reflux overnight, after which the

solvent was evaporated. The remaining solid was taken up in CH_2Cl_2 (500 mL) and 1N HCl (500 mL). The organic layer was washed with 1N HCl (2×250 mL), water (250 mL), and brine (250 mL). After evaporation of the solvent, the remaining solid was recrystallized from CH_2Cl_2 /hexane to give **2** as light gray needles (7.5 g, 89%). M.p. 156–158 °C; ^1H NMR: $\delta = 8.21$ (d, $J = 8.7$ Hz, 2H; ArH), 6.98 (d, $J = 8.7$ Hz, 2H; ArH), 4.21 (t, $J = 5.1$ Hz, 2H; OCH_2), 3.80 (t, $J = 5.1$ Hz, 2H; CH_2O), 3.62 (q, $J = 6.9$ Hz, 2H; CH_2CH_3), 1.25 (t, $J = 6.8$ Hz, 3H; CH_3); ^{13}C NMR: $\delta = 165.1, 142.0, 125.9, 114.2, 69.2, 67.7, 66.7, 15.1$; FAB-MS: m/z (%): 211.2 (100) [M]⁺; elemental analysis calcd (%) for $\text{C}_{10}\text{H}_{13}\text{NO}_4$ (211.1): C 56.87, H 6.20, N 6.63; found: C 57.03, H 6.35, N 6.49.

EG-Cl (3): A suspension of 10% Pd/C (200 mg) in CH_2Cl_2 (200 mL) was stirred for 30 min under a H_2 atmosphere. A solution of **2** (2.11 g, 10.0 mmol) in CH_2Cl_2 (50 mL) was added and the reaction was stirred under a H_2 atmosphere at RT for 12 h. Subsequently, Et_3N (1.21 g, 12.0 mmol) was added, and a solution of chloroacetyl chloride (1.34 g, 12.0 mmol) in CH_2Cl_2 (50 mL) was added dropwise, and stirring was continued under a H_2 atmosphere for another 12 h. The suspension was filtered over Celite and the filtrate was washed with 1N HCl (2×150 mL), water (150 mL), and brine (150 mL), after which it was dried using MgSO_4 . Evaporation of the solvent gave crude **4**, which was purified by column chromatography (silica gel, $\text{CH}_2\text{Cl}_2/\text{MeOH}$ 99:1) to give analytically pure **3** as a light brown solid (2.7 g, 82%, based on **2**). M.p. 132–134 °C; ^1H NMR: $\delta = 8.19$ (brs, 1H; NH), 7.42 (d, $J = 8.8$ Hz, 2H; ArH), 6.91 (d, $J = 8.8$ Hz, 2H; ArH), 4.16 (s, 2H; CH_2Cl), 4.11 (t, $J = 5.1$ Hz, 2H; OCH_2), 3.78 (t, $J = 5.1$ Hz, 2H; CH_2O), 3.61 (q, $J = 6.9$ Hz, 2H; CH_2CH_3), 1.24 (t, $J = 6.8$ Hz, 3H; CH_3); ^{13}C NMR: $\delta = 163.7, 156.3, 129.9, 121.9, 115.0, 68.8, 67.7, 66.8, 42.8, 15.1$; FAB-MS: m/z (%): 257.4 (100) [M]⁺; elemental analysis calcd (%) for $\text{C}_{12}\text{H}_{16}\text{ClNO}_3$ (257.1): C 55.93, H 6.26, N 5.43; found: C 55.78, H 6.21, N 5.40.

EG-SC(O)CH₃ (4): A solution of **3** (2.00 g, 7.78 mmol) in DMF (50 mL) was added dropwise to a suspension of potassium thioacetate (1.05 g, 9.34 mmol) in DMF (10 mL). The solution was stirred overnight in the dark, after which time CH_2Cl_2 (250 mL) was added. The solution was washed with 1N HCl solution (5×200 mL), water (200 mL), and brine (200 mL). After drying with MgSO_4 , the solvent was removed in vacuo, to afford pure **4** as a light brown oil (2.2 g, 95%). ^1H NMR: $\delta = 7.83$ (brs, 1H; NH), 7.39 (d, $J = 8.7$ Hz, 2H; ArH), 6.96 (d, $J = 8.7$ Hz, 2H; ArH), 4.09 (t, $J = 5.1$ Hz, 2H; OCH_2), 3.77 (t, $J = 5.1$ Hz, 2H; CH_2O), 3.60 (q, $J = 6.9$ Hz, 2H; CH_2CH_3), 3.52 (s, 2H; CH_2S), 2.29 (s, 3H; CH_3), 1.22 (t, $J = 6.8$ Hz, 3H; CH_3); ^{13}C NMR: $\delta = 195.0, 166.5, 155.8, 129.7, 121.7, 114.9, 68.9, 67.6, 66.8, 42.7, 32.6, 15.2$; FAB-MS: m/z (%): calcd for $\text{C}_{14}\text{H}_{19}\text{NO}_4\text{S}$: 297.1, found: 297.3 (100) [M]⁺.

EG-SH (5): A solution of **4** (1.00 g, 3.37 mmol) in MeOH (50 mL) was added to a solution of potassium carbonate (2.07 g, 15 mmol) in water (25 mL). N_2 gas was bubbled through the mixture for 20 min, after which time the solution was heated under reflux for 20 min. After the solution had cooled down to RT, 2N HCl solution (200 mL) was added, and the solution was extracted with CH_2Cl_2 (2×100 mL). After washing the combined organic layers with water (100 mL) and brine (100 mL), they were dried with MgSO_4 and evaporated to dryness in vacuo, to give **5** as a brown solid, which was used immediately, without any further purification (0.82 g, 95%). ^1H NMR: $\delta = 7.54$ (brs, 1H; NH), 7.41 (d, $J = 8.7$ Hz, 2H; ArH), 6.91 (d, $J = 8.7$ Hz, 2H; ArH), 4.10 (t, $J = 5.1$ Hz, 2H; OCH_2), 3.80 (t, $J = 5.1$ Hz, 2H; CH_2O), 3.59 (q, $J = 6.9$ Hz, 2H; CH_2CH_3), 3.28 (d, $J = 8.7$ Hz, 2H; CH_2S), 1.92 (t, $J = 8.7$ Hz, 1H; SH), 1.23 (t, $J = 6.9$ Hz, 3H; CH_3).

EG₂Re (6)

i) in organic solvents: N_2 gas was bubbled through a mixture of **5** (0.53 g, 2.00 mmol), NBu_4OAc (0.27 g, 0.90 mmol), and NaOAc (0.32 g, 4.00 mmol) in MeOH (50 mL) for 20 min, after which time the solution was heated under reflux for 15 min. $\text{ReO}(\text{PPh}_3)_2\text{Cl}_3$ (0.76 g, 0.90 mmol) was added, together with CHCl_3 (50 mL), and the solution was again heated under reflux for 5 h. After addition of CHCl_3 (250 mL), the mixture was washed with 1N HCl (250 mL), water (250 mL), and brine (250 mL). Column chromatography (silica gel, $\text{CH}_2\text{Cl}_2/\text{MeOH}$ 9:1) gave **6** as a brown-red oil (0.67 g, 78%). ^1H NMR (CDCl_3): $\delta = 7.15/6.91$ (2d, $J = 8.6$ Hz, $2 \times 4\text{H}$; ArH), 4.13 (t, $J = 5.0$ Hz, 4H; ArOCH_2), 3.83/3.69 (ABq, $J = 17.7$ Hz, $2 \times 2\text{H}$; CH_2S), 3.86 (m, 4H; $\text{ArOCH}_2\text{CH}_2$), 3.60 (q, $J = 7.0$ Hz, 4H; OCH_2CH_3), 2.94 (m, 8H; NCH_2), 1.47 (m, 8H; NCH_2CH_2), 1.34 (m, 8H; CH_2CH_3), 1.24 (t, $J = 6.9$ Hz, 6H; OCH_2CH_3), 0.97 (t, $J = 7.3$ Hz, 12H;

CH_2CH_3); $^1\text{H NMR}$ (400 MHz, D_2O , 30°C): $\delta = 7.08$ (m, 8H; ArH), 4.17 (m, 4H; ArOCH₂), 3.86/3.74 (ABq, $^2J_{\text{AB}} = 15.2$ Hz, 2×2 H; CH₂S), 3.82 (m, 4H; ArOCH₂CH₂), 3.61 (q, $J = 6.8$ Hz, 4H; OCH₂CH₃), 3.21 (m, 8H; NCH₂), 1.57 (m, 8H; NCH₂CH₂), 1.25 (m, 8H; CH₂CH₃), 1.13 (t, $J = 6.8$ Hz, 6H; OCH₂CH₃), 0.85 (m, 12H; CH₂CH₃); $^{13}\text{C NMR}$: $\delta = 195.7, 155.9, 147.5, 129.6, 113.5, 69.1, 67.5, 66.8, 58.6, 39.0, 23.8, 19.7, 15.2, 13.6$; FAB-MS: m/z [^{187}Re , correct isotope pattern], (%): 709.5 (100) (negative mode, $[\text{M} - \text{NBu}_4]^-$), 242.1 (100) (positive mode, $[\text{NBu}_4]^+$).

ii) in water: A $\text{NaRe}(\text{gluc})_2$ solution (2.8 mL, 0.19 mmol), adjusted to pH 10 by the addition of 1 N NaOH (aq), was added to a nitrogen flushed solution of **5** (0.10 g, 0.38 mmol) in water (100 mL). The resulting mixture was flushed with nitrogen for an additional 5 min and then stirred for 1 h at RT. NBu_4OAc (0.06 g, 0.19 mmol) was added and the mixture was extracted with CH_2Cl_2 (3×50 mL). The combined extracts were washed with water (150 mL) and brine (150 mL) and dried using MgSO_4 . The solvent was removed under reduced pressure, giving **6** as a brown-red oil (0.15 g, 83%). Characterization proved it to be identical to **6** synthesized in organic solvents.

iii) in water with native β -CD: A $\text{NaRe}(\text{gluc})_2$ solution (14.84 mL, 0.66 mmol), adjusted to pH 10 by the addition of 1 N NaOH (aq), was added to a nitrogen flushed solution of β -cyclodextrin (2.90 g, 2.55 mmol) and **5** (0.54 g, 2.04 mmol) in water (200 mL). The resulting mixture was flushed with nitrogen for an additional 5 min and then stirred for 1 h at RT. NBu_4OAc (0.20 g, 0.67 mmol) was added and the mixture was extracted with CH_2Cl_2 (3×100 mL). The combined extracts were washed with water (250 mL) and brine (250 mL) and dried using MgSO_4 . The solvent was removed under reduced pressure, giving **6** as a brown-red oil (0.58 g, 93%). Characterization proved it to be identical to **6** synthesized in organic solvents.

AdEt-Cl (8a): According to a literature procedure,^[58] 1-bromoadamantane (**7**) and 2-aminoethanol were combined. The exclusive substitution described on oxygen rather than nitrogen was not observed. Instead, a 3:1 mixture was obtained. To this mixture (0.5 g, 2.56 mmol) and Et_3N (0.51 g, 5.13 mmol) in CH_2Cl_2 (25 mL) was added dropwise a solution of chloroacetyl chloride (0.76 g, 6.66 mmol) in CH_2Cl_2 (25 mL). After stirring overnight at RT, the solution was washed with 2 N HCl solution (3×100 mL), water (100 mL), and brine (100 mL). After drying with MgSO_4 , the solvent was removed in vacuo, to afford a mixture of products which was separated by column chromatography (silica gel, $\text{CH}_2\text{Cl}_2/\text{MeOH}$ 97.5:2.5) to give **8a** as a colorless oil (0.94 g, 71%; max yield: 75%); $^1\text{H NMR}$: $\delta = 7.06$ (brs, 1H; NH), 4.05 (s, 2H; CH₂Cl), 3.52 (m, 2H; OCH₂), 3.43 (m, 2H; CH₂N), 2.15 (brs, 3H; Ad), 1.73 (m, 6H; Ad), 1.62 (m, 6H; Ad); $^{13}\text{C NMR}$: $\delta = 165.6, 72.3, 58.1, 42.5, 41.3, 40.0, 36.2, 30.3$; FAB-MS: m/z (%): calcd for $\text{C}_{14}\text{H}_{22}\text{ClNO}_2$: 271.1, found: 272.2 (100) $[\text{M} + \text{H}]^+$.

AdPr-Cl (8b): A solution of 1-bromoadamantane (**7**, 2.00 g, 9.30 mmol) and triethylamine (3 mL, 21.60 mmol) in 3-amino-1-propanol (30 mL) was heated under reflux overnight. After cooling down to RT, CH_2Cl_2 (150 mL) was added to the mixture, and the resulting solution was washed with 0.1 N NaOH solution (5×100 mL) and with a mixture of brine/1 N NaOH (3:1, 100 mL). After drying the solution with Na_2SO_4 , the solvent was evaporated under reduced pressure to give a crude reaction mixture (1.74 g, 6.09 mmol) which was used without purification. The $^1\text{H NMR}$ spectrum of the crude reaction mixture showed that $\pm 70\%$ of the mixture was the desired product of substitution on the oxygen, the other 30% being the secondary amine. Compound **8b** was synthesized from this mixture according to the procedure described for compound **8a**. The crude product was purified by column chromatography (silica gel, $\text{CH}_2\text{Cl}_2/\text{MeOH}$ 99:1) to give **8b** as an orange-red oil (0.97 g, 56%, max yield: 70%); $^1\text{H NMR}$: $\delta = 7.50$ (brs, 1H; NH), 4.00 (s, 2H; CH₂Cl), 3.55 (t, $J = 5.5$ Hz, 2H; OCH₂), 3.40 (m, 2H; CH₂N), 2.12 (m, 3H; Ad), 1.73 (m, 6H; Ad), 1.73 (m, 2H; OCH₂CH₂), 1.59 (m, 6H; Ad); $^{13}\text{C NMR}$: $\delta = 165.6, 72.4, 59.5, 45.2, 41.4, 39.5, 36.3, 30.4, 28.9$; FAB-MS: m/z (%): calcd for $\text{C}_{15}\text{H}_{24}\text{ClNO}_2$: 285.1, found: 286.1 (100) $[\text{M} + \text{H}]^+$.

AdEt-SC(O)CH₃ (9a): A solution of **8a** (0.30 g, 1.10 mmol) in DMF (10 mL) was added dropwise to a suspension of potassium thioacetate (0.15 g, 1.33 mmol) in DMF (10 mL). The solution was stirred overnight in the dark, after which CH_2Cl_2 (100 mL) was added. The solution was washed with 1 N HCl solution (5×100 mL), water (100 mL), and brine (100 mL). After drying with MgSO_4 , the solvent was removed in vacuo, to afford analytically pure **9a** as a light brown oil (0.33 g, 99%). $^1\text{H NMR}$: $\delta = 6.62$

(brs, 1H; NH), 3.48 (s, 2H; CH₂S), 3.38 (m, 2H; OCH₂), 3.27 (m, 2H; CH₂N), 2.32 (s, 3H; CH₃), 2.08 (brs, 3H; Ad), 1.63 (m, 6H; Ad), 1.55 (m, 6H; Ad); $^{13}\text{C NMR}$: $\delta = 194.7, 166.9, 71.8, 58.7, 41.2, 38.7, 36.2, 33.0, 30.3, 30.2$; FAB-MS: m/z (%): calcd for $\text{C}_{16}\text{H}_{25}\text{NO}_3\text{S}$: 311.2, found: 312.3 (100) $[\text{M} + \text{H}]^+$.

AdPr-SC(O)CH₃ (9b): Compound **9b** was synthesized using compound **8b** according to the procedure described for compound **9a**. The product was obtained as a light brown solid (0.33 g, 95%). M.p. $85 - 89^\circ\text{C}$; $^1\text{H NMR}$: $\delta = 6.82$ (brs, 1H; NH), 3.51 (s, 2H; CH₂S), 3.46 (t, $J = 5.9$ Hz, 2H; OCH₂), 3.29 (m, 2H; CH₂N), 2.35 (s, 3H; CH₃), 2.11 (m, 3H; Ad), 1.70 (m, 6H; Ad), 1.66 (m, 2H; OCH₂CH₂), 1.57 (m, 6H; Ad); $^{13}\text{C NMR}$: $\delta = 194.6, 167.3, 72.1, 58.6, 41.4, 38.8, 36.3, 32.9, 30.3, 30.1, 29.2$; FAB-MS: m/z (%): 326.1 (100) $[\text{M} + \text{H}]^+$; elemental analysis (%) calcd for $\text{C}_{17}\text{H}_{27}\text{NO}_3\text{S} \cdot 0.5\text{H}_2\text{O}$ (334.2): C 61.05, H 8.44, N 4.19, S 9.59; found: C 61.10, H 8.36, N 4.25, S 9.77.

AdEt-SH (10a): A solution of **9a** (0.31 g, 1.00 mmol) in MeOH (40 mL) was added to a solution of potassium carbonate (0.69 g, 5 mmol) in water (20 mL). N_2 gas was bubbled through the mixture for 20 min, after which it was heated under reflux for 20 min. After the solution had cooled down to RT, 2 N HCl solution (200 mL) was added, whereupon the solution was extracted with CH_2Cl_2 (2×100 mL). After washing the combined organic layers with water (100 mL) and brine (100 mL), they were dried with MgSO_4 and evaporated in vacuo, to give **10a** as a brown solid, which was used immediately, without any further purification (0.27 g, 95%). $^1\text{H NMR}$: $\delta = 7.10$ (brs, 1H; NH), 3.54 (m, 2H; OCH₂), 3.42 (m, 2H; CH₂N), 3.25 (d, $J = 8.8$ Hz, 2H; CH₂S), 2.16 (brs, 3H; Ad), 1.90 (t, $J = 8.7$ Hz, 1H; SH), 1.73 (m, 6H; Ad), 1.65 (m, 6H; Ad).

AdPr-SH (10b): Compound **10b** was synthesized using compound **9b** according to the procedure described for compound **10a**. The product was obtained as a colorless oil, which was used immediately, without any further purification (0.30 g, 99%). $^1\text{H NMR}$: $\delta = 7.36$ (brs, 1H; NH), 3.50 (t, $J = 5.5$ Hz, 2H; OCH₂), 3.33 (m, 2H; CH₂N), 3.16 (d, $J = 9.2$ Hz, 2H; CH₂S), 2.10 (m, 3H; Ad), 1.84 (t, $J = 9.2$ Hz, 1H; SH), 1.70 (m, 6H; Ad), 1.68 (m, 2H; OCH₂CH₂), 1.56 (m, 6H; Ad).

trans-AdEt₂Re (*trans*-11a)

i) in organic solvents: N_2 gas was bubbled through a mixture of **10a** (0.22 g, 0.82 mmol), NBu_4OAc (0.11 g, 0.37 mmol), and NaOAc (0.13 g, 1.64 mmol) in MeOH (15 mL) for 20 min, after which it was heated under reflux for 15 min. $\text{ReO}(\text{PPh}_3)_2\text{Cl}_3$ (0.31 g, 0.37 mmol) was added, together with CHCl_3 (10 mL), and the solution was again heated under reflux for 5 h. After addition of CHCl_3 (100 mL), the mixture was washed with 1 N HCl (100 mL), water (100 mL), and brine (100 mL). After drying with MgSO_4 the solvent was evaporated under reduced pressure to give a brown-red oil. Flash column chromatography (silica gel, $\text{CH}_2\text{Cl}_2/\text{MeOH}$ 96:4, slowly increasing to 90:10) gave **11a** as a brown-red oil (0.13 g, 36%). $^1\text{H NMR}$: $\delta = 4.86/4.23$ (2m, 2×2 H; NCH₂), 3.94/3.58 (ABq, $^2J_{\text{AB}} = 17.5$ Hz, 2×2 H; CH₂S), 3.70/3.58 (2m, 2×2 H; CH₂O), 3.17 (m, 8H; NCH₂), 2.12 (brs, 6H; Ad), 1.76 (brs, 12H; Ad), 1.61 (m, 20H; Ad/NCH₂CH₂), 1.43 (m, 8H; CH₂CH₃), 1.02 (t, $J = 7.3$ Hz, 12H; CH₃); $^{13}\text{C NMR}$: $\delta = 196.0, 72.0, 58.6, 58.5, 54.1, 41.7, 41.1, 41.1, 38.8, 36.4, 30.5, 23.8, 21.1, 19.6, 13.5$; FAB-MS: m/z [^{187}Re , correct isotope pattern], (%): 737.5 (100) (negative mode, $[\text{M} - \text{NBu}_4]^-$), 242.1 (100) (positive mode, $[\text{NBu}_4]^+$).

ii) in water with native β -CD (entry 5, Table 1): A solution of **10a** (0.30 g, 1.12 mmol) dissolved in a minimal amount of THF was added to a nitrogen flushed solution of β -cyclodextrin (1.58 g, 1.40 mmol) in water (100 mL). The resulting mixture was flushed with nitrogen for 5 min, after which time $\text{NaRe}(\text{gluc})_2$ solution (8.0 mL, 0.56 mmol), adjusted to pH 10 by the addition of 1 N NaOH (aq), was added to the mixture. The resulting mixture was flushed with nitrogen for an additional 5 min and then stirred for 2.5 h at 55°C . NBu_4OAc (0.17 g, 0.56 mmol) was added and the mixture was extracted with CH_2Cl_2 (3×50 mL). The combined extracts were washed with water (150 mL) and brine (150 mL) and dried using MgSO_4 . The solvent was removed under reduced pressure, giving **11a** as a brown-red oil (0.52 g, 96%). The $^1\text{H NMR}$ spectrum was identical to that of **11a** synthesized in organic solvents, showing only trace amounts of the corresponding *cis* product. Further characterization proved it to be identical to **11a** synthesized in organic solvents.

iii) in water with β -CD dimer $\beta_2\text{dpa}$ (13): This reaction was performed according to **ii**), using **10a** (10 mg, 8.4 μmol), $\text{NaRe}(\text{gluc})_2$ solution (0.22 mL, 4.2 μmol) and using β -CD dimer $\beta_2\text{dpa}$ (**13**) (40 mg, 16.9 μmol)

instead of native β -CD. Yield: 96%. Characterization proved it to be identical to **11a** synthesized in organic solvents.

The β -CD dimer β_2 dpa (**13**) was recovered in 83% yield through dialysis of the aqueous phase (Sigma-D7884, benzoylated cellulose tubing, cutoff ca. 1200 Da; 3 d). ^1H NMR spectroscopy and FAB-MS proved it to be identical to the starting material.

cis-AdEt₂Re (*cis*-**11a**)

in water with native β -CD (entry 2, Table 1): This reaction was carried out according to the synthesis of compound **11a**, method ii), however, the reaction was performed for only 1 h at 0 °C. The ^1H NMR spectrum showed a 51:49 ($\pm 2\%$) mixture of *trans*-**11a** and *cis*-**11a** in an overall yield of 95%. By comparison of the spectrum to the one belonging to pure *trans*-**11a**, the signals belonging to *cis*-**11a** were identified. ^1H NMR: $\delta = 4.80/4.20$ (2m, 2 \times 2H; NCH₂), 4.38/4.09 (ABq, $^2J_{\text{AB}} = 14.2$ Hz, 2 \times 2H; CH₂S), 3.65/3.57 (2m, 2 \times 2H; CH₂O), 3.17 (m, 8H; NCH₂), 2.12 (brs, 6H; Ad), 1.76 (brs, 12H; Ad), 1.61 (m, 20H; Ad and NCH₂CH₂), 1.43 (m, 8H; CH₂CH₃), 1.02 (t, $J = 7.3$ Hz, 12H; CH₃).

AdPr₂Re (**11b**)

i) in organic solvents: Compound **11b** was synthesized according to the procedure described for compound **11a**, instead using compound **10b**. The crude product was purified by column chromatography (silica gel, CH₂Cl₂/MeOH 97:3) to give **11b** as an orange-red oil (0.041 g, 11%). ^1H NMR: $\delta = 4.82/4.05$ (2m, 2 \times 2H; CH₂N), 3.90/3.54 (ABq, $^2J_{\text{AB}} = 17.6$ Hz, 2 \times 2H; CH₂S), 3.50 (t, $J = 7.0$ Hz, 4H; OCH₂), 3.12 (m, 8H; NCH₂), 2.11 (m, 6H; Ad), 1.94/1.87 (2m, 2 \times 1H; OCH₂CH₂), 1.73 (m, 12H; Ad), 1.59 (m, 20H; Ad and NCH₂CH₂), 1.41 (m, 8H; CH₂CH₃), 1.01 (t, $J = 7.3$ Hz, 12H; CH₃); ^{13}C NMR: $\delta = 195.4, 71.6, 58.7, 58.4, 50.3, 41.3, 38.9, 36.3, 31.4, 30.4, 23.8, 19.6, 13.5$; FAB-MS: m/z [¹⁸⁷Re, correct isotope pattern], (%): 765.6 (100) (negative mode, $[\text{M} - \text{NBU}_4]^-$), 242.2 (100) (positive mode, $[\text{NBU}_4]^+$).

ii) in water with native β -CD: A solution of **10b** (0.38 g, 1.34 mmol) dissolved in a minimal amount of methanol was added to a nitrogen flushed solution of β -cyclodextrin (1.90 g, 1.68 mmol) in water (150 mL). The resulting mixture was flushed with nitrogen for 5 min, after which time NaRe(gluc)₂ solution (9.6 mL, 0.66 mmol), adjusted to pH 10 by the addition of 1N NaOH (aq), was added to the mixture. The resulting mixture was flushed with nitrogen for an additional 5 min and then stirred for 5 h at 55 °C. NBU₄OAc (0.20 g, 0.67 mmol) was added and the mixture was extracted with CH₂Cl₂ (3 \times 50 mL). The combined extracts were washed with water (150 mL) and brine (150 mL) and dried with MgSO₄. The solvent was removed under reduced pressure, giving **11b** as an orange-red oil (0.63 g, 95%). Characterization proved it to be identical to **11b** synthesized in organic solvents.

TBDMS-protected β_2 (benz) (12a**):** NaH (60% dispersion in oil, 84 mg, 2.1 mmol) was added to a solution of dried (100 °C, 0.1 mbar, 5 h) TBDMS-protected β -cyclodextrin (4.0 g, 2.1 mmol) in THF (100 mL). The mixture was stirred for 1 h at RT and then for 2 h at reflux. After addition of 4,4'-bis(bromomethyl)benzophenone (100 mg, 0.27 mmol) reflux was continued for 5 d. The solvent was removed in vacuo and chloroform was added. The solution was washed with 1M HCl, water, and brine, and dried (MgSO₄). After removal of the solvent and purification by column chromatography (silica gel, ethyl acetate/ethanol/water 100:2:1) the product was obtained as a colorless powder (0.099 g, 9%). ^1H NMR (300 MHz, CDCl₃/CD₃OD, 25 °C): $\delta = 7.80$ (d, 4H, $J = 7.7$ Hz; Ar-H), 7.52 (d, 4H, $J = 7.7$ Hz; Ar-H), 5.07–4.84 (m, 14H; H-1), 4.34–3.15 (m, 88H; H-2, H-3, H-4, H-5, H-6, Ar-CH₂), 0.95–0.81 (m, 126H; CH₃-C), 0.11–0.00 (m, 84H; CH₃-Si); MS (FAB) m/z : calcd for C₁₈₃H₃₄₆O₇₁Si₁₄: 4075.1, found: 4099.1 $[\text{M} + \text{Na}]^+$.

β_2 (benz) (12**):** TBDMS-protected β_2 (benz) (80 mg, 0.020 mmol) was dissolved in THF (5 mL). After addition of a 1M solution of tetrabutylammonium fluoride in THF (0.7 mL) the solution was stirred overnight at ambient temperature. The solvent was removed in vacuo and the residue dissolved in water. After three washings with hexane, salts were removed over Amberlite MB-3A ion-exchange resin. After freeze-drying the dimer was obtained as a colorless powder (0.035 g, 70%). ^1H NMR (300 MHz, D₂O, 25 °C): $\delta = 7.62$ (d, 4H, $J = 7.8$ Hz; Ar-H), 7.46 (d, 4H, $J = 7.9$ Hz; Ar-H), 4.91–4.86 (m, 14H; H-1), 3.96–3.15 (m, 88H; H-2, H-3, H-4, H-5, H-6, Ar-CH₂); MS (FAB) m/z : calcd for C₉₉H₁₅₀O₇₁: 2474.7, found: 2476.8 $[\text{M} + \text{H}]^+$.

Thioacetic acid S-pyridin-2-ylmethyl ester (16**):**^[59] A suspension of potassium thioacetate (2.51 g, 22.00 mmol), K₂CO₃ (5.5 g, 40.00 mmol),

and **15**·HCl (3.28 g, 20.00 mmol) in DMF (50 mL) was stirred overnight in the dark, after which CH₂Cl₂ was added (500 mL). The solution was washed with 0.5N HCl solution (5 \times 500 mL), water (500 mL), and brine (500 mL). After drying with MgSO₄, the solvent was removed in vacuo, removing trace amounts of DMF by repeated azeotropic distillation with toluene to afford **16** as a light brown oil (2.8 g, 85%). ^1H NMR: $\delta = 8.53$ (d, $J = 5.8$ Hz, 1H; PyrH), 7.62 (t, $J = 7.7$ Hz, 1H; PyrH), 7.34 (d, $J = 7.7$ Hz, 1H; PyrH), 7.16 (t, $J = 6.4$ Hz, 1H; PyrH), 4.26 (s, 2H; CH₂S), 2.36 (s, 3H; CH₃); ^{13}C NMR: $\delta = 194.8, 149.4, 136.7, 123.1, 122.2, 122.1, 35.3, 30.2$; FAB-MS: m/z [glycerol] (%): calcd for C₈H₉NOS: 167.0, found: 168.1 (100) $[\text{M} + \text{H}]^+$.

Pyridin-2-yl-methanethiol (17**):**^[60] A solution of **16** (1.00 g, 6.00 mmol) in MeOH (40 mL) was added to a solution of potassium carbonate (1.25 g, 9.00 mmol) in water (20 mL). N₂ gas was bubbled through the mixture for 20 min, after which it was heated under reflux for 30 min. After the solution had cooled to RT, 1N HCl solution (200 mL) was added, and the solution was extracted with CH₂Cl₂ (2 \times 100 mL). After washing the combined organic layers with water (100 mL) and brine (100 mL), they were dried with MgSO₄ and evaporated in vacuo, to give **10a** as a brown solid (0.62 g, 82%), which was used immediately, without any further purification. ^1H NMR: $\delta = 8.56$ (m, 1H; PyrH), 7.66 (m, 1H; PyrH), 7.35 (m, 1H; PyrH), 7.16 (m, 1H; PyrH), 3.86 (d, $J = 7.7$ Hz, 2H; CH₂S), 2.02 (t, $J = 7.7$ Hz, 1H; SH).

AdPr-Pyr-Re (**18**)

i) in organic solvents: A suspension of ReO(PPh₃)₂Cl₃ (1.53 g, 1.83 mmol) in CHCl₃ (10 mL) was added to a solution of **17** (0.23 g, 1.83 mmol) and **10b** (0.52 g, 1.83 mmol) in 1N NaOAc/MeOH (20 mL). The mixture was stirred at 75 °C for 30 min, after which time it was partitioned between water and CH₂Cl₂ (200 mL each). The organic layer was washed with water (200 mL) and brine (3 \times 200 mL) after which it was dried using MgSO₄. Removal of the solvent in vacuo gave a solid which was purified by flash column chromatography (silica gel, CH₂Cl₂, slowly increasing to CH₂Cl₂/MeOH 98.5:1.5) to give **18** as a purple oil (0.50 g, 45%). ^1H NMR: $\delta = 9.68$ (d, $J = 5.8$ Hz, 1H; PyrH), 8.16 (dt, $J = 7.7, 1.2$ Hz, 1H; PyrH), 8.04 (d, $J = 7.7$ Hz, 1H; PyrH), 7.65 (t, $J = 6.4$ Hz, 1H; PyrH), 5.34/4.12 (2m, 2 \times 1H; CH₂N), 5.32/4.23 (ABq, $J = 19.6$ Hz, 2 \times 1H; PyrCH₂S), 4.07/3.66 [ABq, $J = 17.5$ Hz, 2 \times 1H; C(O)CH₂S], 3.53 (m, 2H; CH₂O), 2.15 (m, 3H; Ad), 1.93 (m, 2H; OCH₂CH₂), 1.78 (brs, 6H; Ad), 1.63 (m, 6H; Ad); ^{13}C NMR: $\delta = 172.6, 156.2, 142.1, 125.2, 122.3, 58.0, 54.9, 52.2, 41.6, 38.1, 36.6, 31.1, 30.6$; FAB-MS: m/z [¹⁸⁷Re, correct isotope pattern], (%): calcd for C₂₁H₂₉N₂O₅S₂Re: 608.1, found: 609.1 (100) $[\text{M} + \text{H}]^+$.

ii) in water with native β -CD: A solution of **17** (0.11 g, 0.89 mmol) and **10b** (0.25 g, 0.89 mmol) in a minimal amount of THF was added to a nitrogen flushed solution of β -cyclodextrin (2.12 g, 1.87 mmol) in water (175 mL). The resulting mixture was flushed with nitrogen for 5 min, after which time NaRe(gluc)₂ solution (12.9 mL, 0.89 mmol), adjusted to pH 10 by the addition of 1N NaOH (aq), was added to the mixture. The resulting mixture was flushed with nitrogen for an additional 5 min and then stirred for 5 h at 55 °C, after which time the mixture was extracted with CH₂Cl₂ (3 \times 100 mL). The combined extracts were washed with water (250 mL) and brine (250 mL) and dried with MgSO₄. The solvent was removed under reduced pressure, giving an oil which was purified by flash column chromatography (silica gel, CH₂Cl₂, slowly increasing to CH₂Cl₂/MeOH 98.5:1.5) to give **18** as a purple oil (0.43 g, 79%). Characterization proved it to be identical to **18** synthesized in organic solvents.

Cyclodextrin-modified cytochrome C (21**):** A solution of *N*-succinimidyl-S-acetylthioacetate (2 mg, 8.4 μmol) in DMF (50 μL) was added to a solution of cyclodextrin-dimer **13** (10 mg, 4.2 μmol) in aqueous phosphate buffer (0.05 M, pH 7.5, 1 mL). After 10 min at RT, the modified dimer was purified using a PD-10 column. To the cyclodextrin-containing fractions, a solution of NH₂OH·HCl (300 μL , 0.5 M) in phosphate buffer pH 7.5 was added and allowed to react for 1 h to obtain the free thiol **19**.

While the reaction vessel was vortexed, a solution of *N*-succinimidyl-6-maleimidocaproate (0.9 mg, 3 μmol) in DMF (10 μL) was added to a solution of cytochrome C (9 mg, 0.7 μmol) in phosphate buffer pH 8 (0.5 mL). After vortexing 5 min at RT, phosphate buffer pH 6 (0.5 mL) was added and the product **20** was purified over a PD-10 column that had previously been equilibrated at pH 6. At RT, the solution of the thiol-containing cyclodextrin dimer was slowly added to the solution of the modified cytochrome C and allowed to react for 2 h. After dialysis against phosphate buffer pH 6.9 (2 \times 2.5 L, 24 h) and purified water (2.5 L, 24 h),

lyophilization yielded a mixture of products as a red powder (6 mg, 67%). MALDI-MS: m/z : calcd for [Cyt C+5 × maleimide+19] = 15868, found: 15868, 13301 [Cyt C+5 × maleimide], 6652 [Cyt C+5 × maleimide]²⁺, 7934 [Cyt C+5 × maleimide+19]²⁺, 26728 ($\approx 2 \times 13301$), and 29196 ($\approx 13301+15868$). The last two values are minor peaks, probably caused by formation of disulfide bonds between two cytochrome C molecules.

Determination of the association constants by fluorescence titrations: Fluorescence measurements were performed on an Edinburgh SF 900 spectrometer. Sample solutions were prepared using a phosphate buffer (pH 7, $I = 0.02\text{ M}$) in pure water (Millipore Q2).

AdEt₂Re **11a** or AdPr₂Re **11b**, with β₂dans **14**: Aliquots of guest (**11a** or **11b**) (4.7×10^{-5} , $1.3 \times 10^{-4}\text{ M}$, respectively) in MeOH were added in a given MeOH/water mixture to a solution of β₂dans **14** (7.2×10^{-7} , $7.0 \times 10^{-7}\text{ M}$, respectively). A correction for the MeOH addition was done by performing the same titration using pure MeOH and subtracting these values from the values obtained for the methanolic solution of the guest ($\lambda_{\text{ex}} = 335\text{ nm}$).

Crystal structure determinations

trans-AdEt₂Re (11a): C₆₀H₁₀₀MgN₄O₁₄Re₂S₄ · 2C₂₈H₄₂N₂O₃ReS₂ · MgC₆H₂₄O₆ · 2CH₄O, $M_r = 3413.07$, red-brown, plate-shaped crystal ($0.05 \times 0.10 \times 0.25\text{ mm}$), monoclinic, space group $P2_1/c$ (no. 14) with $a = 26.866(2)$, $b = 7.2780(6)$, $c = 36.369(3)\text{ \AA}$, $\beta = 98.880(6)^\circ$, $V = 7026.0(1)\text{ \AA}^3$, $Z = 2$, $\rho_x = 1.613\text{ g cm}^{-3}$, $F(000) = 3480$, $\mu(\text{MoK}\alpha) = 3.83\text{ mm}^{-1}$. Where relevant, the contribution of the disordered counterions and solvent molecules has been included in the reported data (see below). 107528 Reflections measured, 12725 independent reflections, $R_{\text{int}} = 0.1234$, ($1.6^\circ < \theta < 25.25^\circ$, $T = 150\text{ K}$, MoK α radiation, graphite monochromator, $\lambda = 0.71073\text{ \AA}$). Data were collected on an Enraf–Nonius KappaCCD area detector on rotating anode and corrected for absorption by a multi-scan method (PLATON/MULABS).^[61] The structure was solved by direct methods SHELXS-97,^[62] and refined on F^2 using SHELXL-97-2.^[62] The unit cell contains two symmetry-related cavities (438 \AA^3 each), filled with disordered Mg(MeOH)₆²⁺ counterions and solvent molecules, probably methanol. No satisfactory model could be refined. This disordered density was taken into account with the squeeze procedure, as implemented in PLATON.^[61] Hydrogen atoms were included in the refinement on calculated positions riding on their carrier atoms. All non-hydrogen atoms were refined with anisotropic displacement parameters. Hydrogen atoms were refined with a fixed isotropic displacement parameter related to the value of the equivalent isotropic displacement parameter of their carrier atoms. Final $wR2 = 0.0989$, $w = 1/[\sigma^2(F^2) + (0.0407P)^2 + 7.94P]$, where $P = (\max(F_o^2, 0) + 2F_c^2)/3$, $R1 = 0.0518$ (for $10541\ I > 2\sigma(I)$), $S = 1.110$, 727 refined parameters, $-1.09 < \Delta\rho < 0.84\text{ e \AA}^{-3}$.

AdPr-Pyr-Re (18): C₂₁H₂₉N₂O₃ReS₂, $M_r = 607.81$, purple, block-shaped crystal ($0.20 \times 0.25 \times 0.30\text{ mm}$), monoclinic, space group $P2_1/c$ (no. 14) with $a = 14.7391(15)$, $b = 16.9273(12)$, $c = 18.5105(18)\text{ \AA}$, $\beta = 110.283(12)^\circ$, $V = 4331.9(8)\text{ \AA}^3$, $Z = 8$, $\rho_x = 1.864\text{ g cm}^{-3}$, $F(000) = 2400$, $\mu(\text{MoK}\alpha) = 5.828\text{ mm}^{-1}$, 33132 Reflections measured, 9868 independent reflections, $R_{\text{int}} = 0.0586$, ($1.6^\circ < \theta < 27.48^\circ$, $T = 150\text{ K}$, MoK α radiation, graphite monochromator, $\lambda = 0.71073\text{ \AA}$). Data were collected on an Enraf–Nonius KappaCCD area detector on rotating anode and corrected for absorption by a multi-scan method (PLATON/MULABS).^[61] The structure was solved by direct methods (SHELXS86)^[63] and refined on F^2 using SHELXL-97-2.^[62] The adamantoyl moiety of one of the independent molecules is disordered over two positions. A disorder model was introduced; the occupancy of the major component refined to 0.566(6). Mild distance restraints were introduced to ensure reasonable geometries of the major and minor components. Hydrogen atoms were included in the refinement on calculated positions riding on their carrier atoms. All ordered non-hydrogen atoms were refined with anisotropic displacement parameters; the disordered atoms were refined isotropically. Hydrogen atoms were refined with a fixed isotropic displacement parameter related to the value of the equivalent isotropic displacement parameter of their carrier atoms. Final $wR2 = 0.0985$, $w = 1/[\sigma^2(F^2) + (0.0322P)^2 + 9.96P]$, where $P = (\max(F_o^2, 0) + 2F_c^2)/3$, $R1 = 0.0387$ (for $6689\ I > 2\sigma(I)$), $S = 1.039$, 501 refined parameters, $-2.05 < \Delta\rho < 1.88\text{ e \AA}^{-3}$.

Crystallographic data (excluding structure factors) for the structures reported in this paper have been deposited with the Cambridge Crystallographic Data Centre as supplementary publication no. CCDC-157763 (**11a**) and CCDC 157764 (**18**). Copies of the data can be obtained free of

charge on application to CCDC, 12 Union Road, Cambridge CB21EZ, UK (fax: (+44) 1223-336-033; e-mail: deposit@ccdc.cam.ac.uk).

Acknowledgement

We are grateful to the Council for Chemical Sciences of the Netherlands Organization for Scientific Research (NWO-CW) and the Technology Foundation STW for financial support in the framework of the CW/STW program Technical Chemistry (project number 349-4213, MRdJ), and to Dirk Rijkers for valuable discussions on the labeling of proteins.

- [1] For recent reviews of medicinal inorganic chemistry in general, or (rhenium) radiopharmaceuticals in specific see: a) *Chem. Rev.* **1999**, *99*, Issue 9; b) Z. Guo, P. J. Sadler, *Angew. Chem.* **1999**, *111*, 1610–1630; *Angew. Chem. Int. Ed.* **1999**, *38*, 1513–1531; c) K. Schwochau, *Angew. Chem.* **1994**, *106*, 2349–2358; *Angew. Chem. Int. Ed. Engl.* **1994**, *33*, 2258–2267; d) J. R. Dilworth, S. J. Parrot, *Chem. Soc. Rev.* **1998**, *27*, 43–55.
- [2] For reviews on CD chemistry see *Chem. Rev.* **1998**, *98*, Issue 5.
- [3] J. Szejtli, *Med. Res. Rev.* **1994**, *14*, 353–386.
- [4] K. Uekama, F. Hirayama, T. Irie, *Chem. Rev.* **1998**, *98*, 2045–2076.
- [5] S. D. Eastburn, B. Y. Tao, *Biotech. Adv.* **1994**, *12*, 325–339.
- [6] β-CD dimer complexes with potential applications in photodynamic therapy have been reported: a) J. G. Moser, A. Ruebner, A. Vervoorts, B. Wagner, *J. Incl. Phenom. Macromol. Chem.* **1996**, *25*, 29–34; b) A. Ruebner, J. G. Moser, D. Kirsch, B. Spengler, S. Andrees, S. Roehrs, *J. Incl. Phenom. Macromol. Chem.* **1996**, *25*, 35–38; c) A. Ruebner, D. Kirsch, S. Andrees, W. Decker, B. Roeder, B. Spengler, R. Kaufmann, J. G. Moser, *J. Incl. Phenom. Macromol. Chem.* **1997**, *27*, 69–84; d) A. Ruebner, Z. Yang, D. Leung, R. Breslow, *Proc. Natl. Acad. Sci. USA* **1999**, *96*, 14692–14693.
- [7] F. Hirayama, K. Uekama, *Adv. Drug Delivery Rev.* **1999**, *36*, 125–141.
- [8] K. H. Frömming, J. Szejtli, *Cyclodextrins in Pharmacy*, Kluwer Academic Publisher, Dordrecht, **1993**, p. 324.
- [9] J. Szejtli, *Cyclodextrin Technology*, Kluwer Academic Publisher, Dordrecht, **1988**, p. 450.
- [10] G. N. Kalinkova, *Int. J. Pharm.* **1999**, *187*, 1–15.
- [11] D. W. Oliver, I. C. Dormehl, W. Louw, E. Kilian, V. de Beco, J. L. Morretti, *Arzneimittel Forsch.* **2000**, *50*, 758–764.
- [12] C. Bolzati, A. Boschi, L. Uccelli, A. Duatti, R. Franceschini, A. Piffanelli, *Nucl. Med. Biol.* **2000**, *27*, 309–314.
- [13] K. Takahashi, *Chem. Rev.* **1998**, *98*, 2013–2033.
- [14] Probably, the [Mg(MeOH)₆]²⁺ originates from the drying agent MgSO₄, the Mg²⁺ complexing with the methanol present.
- [15] K. J. C. van Bommel, W. Verboom, R. Hulst, H. Kooijman, A. L. Spek, D. N. Reinhoudt, *Inorg. Chem.* **2000**, *39*, 4099–4206.
- [16] M. R. de Jong, J. F. J. Engbersen, J. Huskens, D. N. Reinhoudt, *Chem. Eur. J.* **2000**, *6*, 4034–4040.
- [17] $K_1 = \frac{[HG]}{[H][G]}$ and $K_2 = \frac{[H_2G]}{[H][HG]}$, where H (host) is β-CD and G (guest) is **6**. A least squares fitting procedure was used while independently varying K_1 , K_2 , and the free and bound shift values, using a spreadsheet methodology developed before: J. Huskens, H. van Bekkum, J. A. Peters, *Comp. Chem.* **1995**, *19*, 409–416.
- [18] K. A. Connors, *J. Pharm. Sci.* **1995**, *84*, 843–848.
- [19] K. A. Connors, *Binding constants, the measurement of molecular complex stability*, Wiley, New York, **1987**, Chapter 4.
- [20] The deviation from 0.5 may be caused by the presence of small amounts of (EG₂Re)₂ ⊂ β₂benz.
- [21] CPK molecular models suggest that only one of the two aromatic rings can be complexed at any given time, due to the distance between the β-CD moieties. NMR spectra indicate that there is a rapid exchange between the extremes, that is, either one of the aromatic rings inside a β-CD cavity.
- [22] The error in the individual log K_{obs} values is estimated to be ±0.3.
- [23] K. A. Connors, M. J. Mulski, A. Paulson, *J. Org. Chem.* **1992**, *57*, 1794–1798.

- [24] The formula $\delta_M \Delta G^0 = \frac{[g\Delta A(\gamma_2 - \gamma_1) + kT \ln K_1] K_1 x_1}{x_1 + K_1 x_2}$, as derived by Connors et al. (ref. [23]) was used to obtain the association constants for the complexation of the bisadamantane guests by β_2 dans **14** in pure water. ΔG^0 = total free energy change; g = curvature correction factor to the surface tension; ΔA = decrease in surface area resulting from the coalescence of two solvent cavities (containing substrate and ligand molecules); γ = solvent surface tension; $K_1 = K_M/K_W$, with K_M and K_W being the equilibrium constants for the following two equilibria: $L+W \rightleftharpoons LW$ and $L+M \rightleftharpoons LM$, respectively; x_1, x_2 = bulk mol fractions of water and organic cosolvent. Using $\gamma_1 - \gamma_2 = 6.5 \times 10^{-22} \text{ J } \text{Å}^{-2}$ and $K_1 = 4.9$ (values used by Connors et al.), the following value was obtained for $-g\Delta A$: $50 \text{ Å}^2 \text{ molec}^{-1}$. A similar value was obtained by Connors et al.: $-g\Delta A = 43 \text{ Å}^2 \text{ molec}^{-1}$. (Since the error in the fitting procedure proved not very sensitive to changes in K_1 , the reported value of 4.9 could be used for the fitting procedure.)
- [25] When the fitting parameters are optimized independently for the two datasets of Figure 8, the optimized $\log K$ value for the binding of AdPr_2Re **11b** by β -CD dimer β_2 dans **14** is 10.3 ± 1.0 .
- [26] For the different aspects of rhenium radiopharmaceuticals see the review of Dilworth and Parrot, ref. [1d].
- [27] B. Johannsen, R. Syhre, *Radiochem. Radioanal. Lett.* **1978**, *36*, 107–110.
- [28] B. Noll, T. Knies, M. Freibe, H. Spies, B. Johannsen, *Isotopes Environ. Health Stud.* **1996**, *32*, 21–29.
- [29] Rhenium(v) gluconate was synthesized according to an adapted literature procedure (ref. [28]), using NaReO_4 instead of NBU_4ReO_4 .
- [30] It proved necessary to add one equivalent of a lipophilic cation (NBU_4^+) to facilitate extraction of the formed complexes to the organic layer.
- [31] The ^1H NMR signals belonging to compound *cis*-**11a** are listed in the Experimental Section.
- [32] Due to the degree of symmetry present in both the *cis* as well as the *trans* complex, the structure of the two complexes could not be proven with NMR.
- [33] Only one example of preferential product formation using a CD-dimer has been reported, however, without stereoselectivity: C. J. Easton, J. B. Harper, S. F. Lincoln, *New J. Chem.* **1998**, 1163–1165.
- [34] a) D. H. Busch, A. L. Vance, A. G. Kolchinski, in *Comprehensive Supramolecular Chemistry*, Vol. 9 (Eds.: J.-P. Sauvage, M. W. Hosseini), Elsevier, Amsterdam/New York, **1996**, p. 1; b) R. G. Chapman, J. C. Sherman, *Tetrahedron* **1997**, *53*, 15911–15945.
- [35] D. Y. Chi, J. A. Katzenellenbogen, *J. Am. Chem. Soc.* **1993**, *115*, 7045–7046.
- [36] R. K. Hom, D. Y. Chi, J. A. Katzenellenbogen, *J. Org. Chem.* **1996**, *61*, 2624–2631.
- [37] The other bis(bidentate) complexes were not isolated.
- [38] Besides the three bis(bidentate) complexes, TLC showed several other spots belonging to compounds which were not identified.
- [39] Although actual complexation of the pyridine ligand by β -CD has not been established here, pyridine derivatives are known to form inclusion complexes with β -CD: a) I. Satake, S. Yoshida, K. Hayakawa, T. Maeda, Y. Kusumoto, *Bull. Chem. Soc. Jpn.* **1986**, *59*, 3991–3993; b) M. Cotta Ramusino, L. Rufini, C. Mustazza, *J. Inclusion Phenom. Mol. Recogn.* **1993**, *15*, 359–368.
- [40] When synthesizing the complex using $\text{ReO}(\text{PPh}_3)_2\text{Cl}_3$, the crude products contained PPh_3 and occasionally PPh_3O , making purification somewhat troublesome.
- [41] a) F. Djedaïni-Pilard, J. Désalos, B. Perly, *Tetrahedron Lett.* **1993**, *34*, 2457–2460; b) M. K. Hristova-Kazermieski, P. Horan, P. Davis, H. I. Yamamura, T. Kramer, R. Horvath, W. M. Kazermieski, F. Porreca, V. J. Hruby, *Bioorg. Med. Chem. Lett.* **1993**, *3*, 831–834; c) N. Schaske, S. Fiori, E. Weyher, C. Escricut, D. Fourmy, G. Müller, L. Moroder, *J. Am. Chem. Soc.* **1998**, *120*, 7030–7038.
- [42] a) N. Schaske, I. Assfalg-Machleidt, W. Machleidt, T. Lassleben, C. P. Sommerhoff, L. Moroder, *Biorg. Med. Chem. Lett.* **2000**, *10*, 677–680; b) C. Péan, C. Créminon, A. Wijkhuizen, J. Grassi, P. Guenot, P. Jehan, J.-P. Dalbiez, B. Perly, F. Djedaïni-Pilard, *J. Chem. Soc. Perkin Trans. 2* **2000**, 853–863.
- [43] S. Liu, S. Edwards, *Chem. Rev.* **1999**, *99*, 2235–2268.
- [44] J. M. Peeters, T. G. Hazendonk, E. C. Beuvery, G. I. Tesser, *J. Immunol. Methods* **1989**, *120*, 133–143.
- [45] R. J. S. Duncan, P. D. Weston, R. Wigglesworth, *Anal. Biochem.* **1983**, *132*, 68–73.
- [46] A. Bax, R. Freeman, *J. Magn. Reson.* **1981**, *44*, 542–546.
- [47] A. Bax, D. G. Davis, *J. Magn. Reson.* **1985**, *65*, 355–60.
- [48] J. Jeener, B. M. Meier, P. Bachmann, R. R. Ernst, *J. Chem. Phys.* **1979**, *71*, 4546–4553.
- [49] A. Bax, R. H. Griffey, B. L. Hawkins, *J. Magn. Reson.* **1983**, *55*, 301–315.
- [50] D. J. States, R. A. Haberkorn, D. J. Ruben, *J. Magn. Reson.* **1982**, *48*, 286–292.
- [51] M. Karas, D. Bachmann, U. Bahr, F. Hillenkamp, *Int. J. Mass Spectrom. Ion Processes* **1987**, *78*, 53–68.
- [52] F. Hillenkamp, M. Karas, *Anal. Chem.* **1991**, *63*, A1193-A1202.
- [53] K. Tanaka, H. Waki, Y. Ido, S. Akita, Y. Yoshida, T. Yoshida, *Rapid Commun. Mass Spectrom.* **1988**, *2*, 151–153.
- [54] M. L. Vestal, P. Juhasz, S. A. Martin, *Rapid Commun. Mass Spectrom.* **1995**, *9*, 1044–1050.
- [55] H.-F. Grützmacher, W. Husemann, *Tetrahedron* **1987**, *43*, 3205–3212.
- [56] E. van Dienst, B. H. M. Snellink, I. Von Piekartz, M. H. B. Grote Gansey, F. Venema, M. C. Feiters, R. J. M. Nolte, J. F. J. Engbersen, D. N. Reinhoudt, *J. Org. Chem.* **1995**, *60*, 6537–6545.
- [57] Compound **2** has been described in patents only: Ciba-Geigy, DE 2749902 [*Chem. Abstr.* **1978**, *89*, 112428].
- [58] J. K. Chakrabarti, M. J. Foulis, S. S. Szinai, *Tetrahedron Lett.* **1968**, 6249–6252.
- [59] This compound was synthesized before, however, using pyridin-2-yl-methanol and thioacetic acid: ref. [60].
- [60] Synthesized according to an adapted literature procedure: R. Deziel, E. Malenfant, *Bioorg. Med. Chem. Lett.* **1998**, *8*, 1437–1442.
- [61] A. L. Spek, *PLATON—A multi-purpose crystallographic tool*, Utrecht University, The Netherlands, **1999**; Internet: <http://www.cryst.chem.uu.nl/platon>.
- [62] G. M. Sheldrick, *SHELXL-97: Program for crystal structure refinement*, University of Göttingen, Germany, **1997**.
- [63] G. M. Sheldrick, *SHELXS86: Program for crystal structure determination*, University of Göttingen, Germany, **1986**.

Received: February 16, 2001 [F3079]